

ME-160

Mechanical Engineering Drawing



Course Teachers:
Musanna Galib
Saif Al-Afsan Shamim
Abdul Aziz Shuvo

Course Outcomes:

- Students will be able to understand the theory of projection. To improve the visualization skills.
- Students will be able to know and understand the conventions and the methods of engineering drawing.
- By the end of this course, the students will be able to identify the orthographic views of a given 3D objects precisely.
- Will be able to predict the isometric view of an object from the given orthographic views correctly.
- Will also be able to sketch auxiliary and sectional views of an
Object if needed.

Course Syllabus:

- Introduction
- Basic concepts of engineering drawing
- Instruments and their uses
- First and third angle projections
- Orthographic drawings; Principal views, Isometric views; Missing lines and views; Sectional views ; Auxiliary views.

Text book:

- Mechanical Engineering Drawing
-by Dr. Md. Quamrul Islam

Reference books :

- Fundamentals of Engineering Drawing
-by French & Vierck.
- Metric Drafting
– by Paul Wallah.
- Drafting Technology and Practice
– by William P. Spence

Class Schedule

1. Introduction: Basic Drawing Practice
2. Orthogonal views of simple block
3. Orthogonal views with circular holes
4. Orthogonal views with fillets and rounds
5. Sectional views
6. Sectional views (With Ribs and Fillets)
7. Auxiliary views
8. Isometric views
9. Isometric views with circular holes
10. Missing Lines and Missing views.

Points to be noted...

- No student will be allowed in the class without necessary **INSTRUMENTS** and **INSTRUCTION SHEET.**
- There will be a **QUIZ EXAM** and an **ORAL EXAM** during the term time. Marks obtained in these exams and those in drawing performed in the classes will be added together to calculate the final grade.

Attendance	Class Performance	Viva	Final Quiz	Total
10%	40%	10%	40%	100%

Graphics Language

Effectiveness of Graphics Language

1. Try to write a description of this object.
 2. Test your written description by having someone attempt to make a sketch from your description.
-



You can easily understand that ...

The word languages are inadequate for describing the **size**, **shape** and **features** completely as well as concisely.

Composition of Graphic Language

Graphic language in “**engineering application**” use **lines** to represent the **surfaces**, **edges** and **contours** of objects.

The language is known as “**drawing**” or “**drafting**” .

A drawing can be done using **freehand**, **instruments** or **computer** methods.

Freehand drawing

The lines are sketched without using instruments other than pencils and erasers.

Example

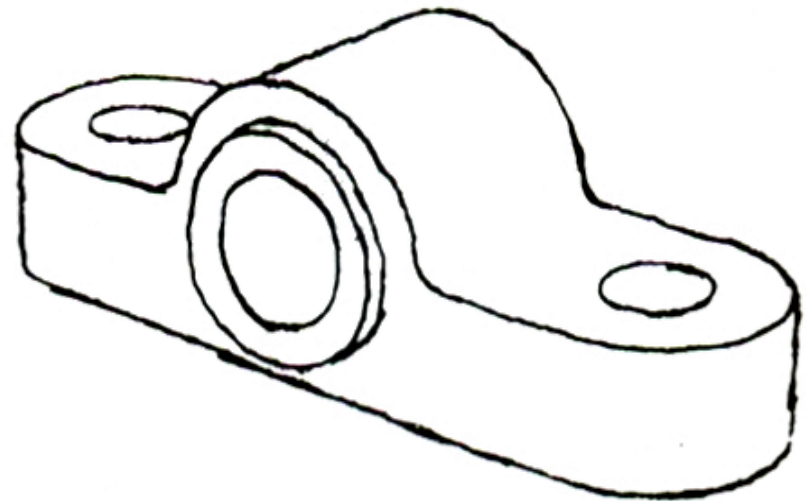
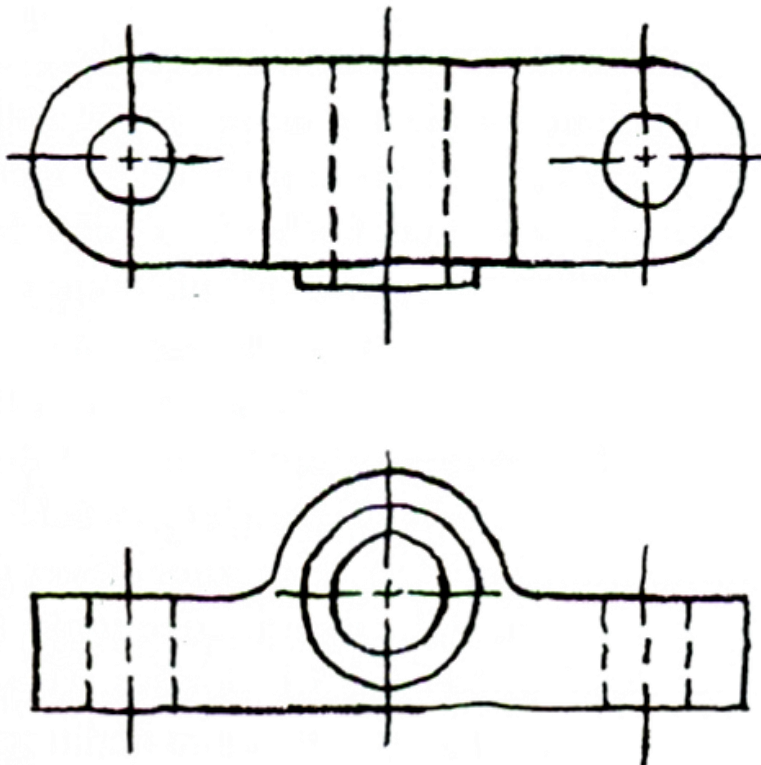

Instrument drawing

Instruments are used to draw straight lines, circles, and curves concisely and accurately. Thus, the drawings are usually made to scale.

Example

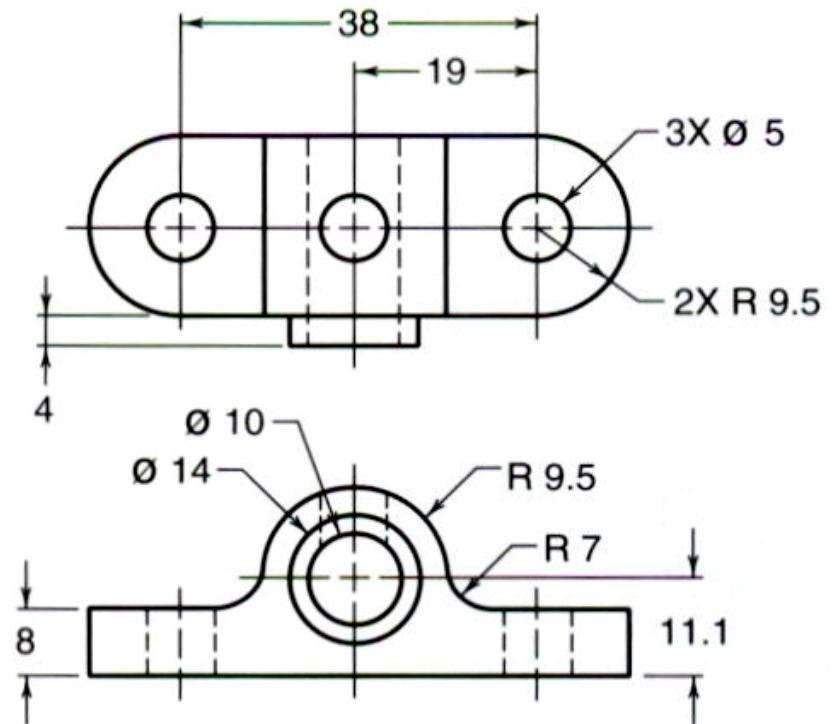

Computer drawing

The drawings are usually made by commercial software such as AutoCAD, solid works etc.

Example



Engineering Drawing

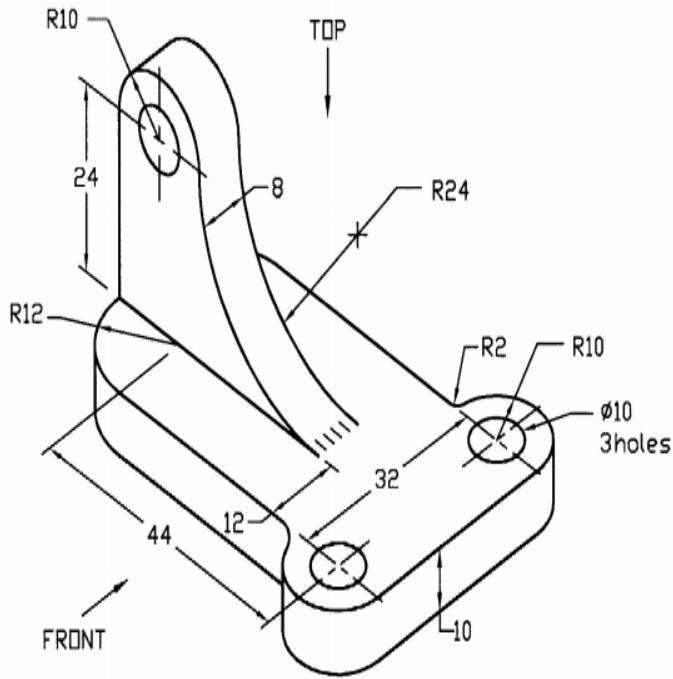

Suppose you want the block shown in the figure for certain project/thesis. Manufacturer will want to know the dimensions, hole no. etc. for building this object.

The end goal of an engineering drawing is to convey all the required information that will allow a manufacturer to produce that component.

Elements of Engineering Drawing

Engineering drawing are made up of *graphics language* and *word language*.

Graphics language

Describe a shape (mainly).

Word language

Describe size, location and specification of the object.

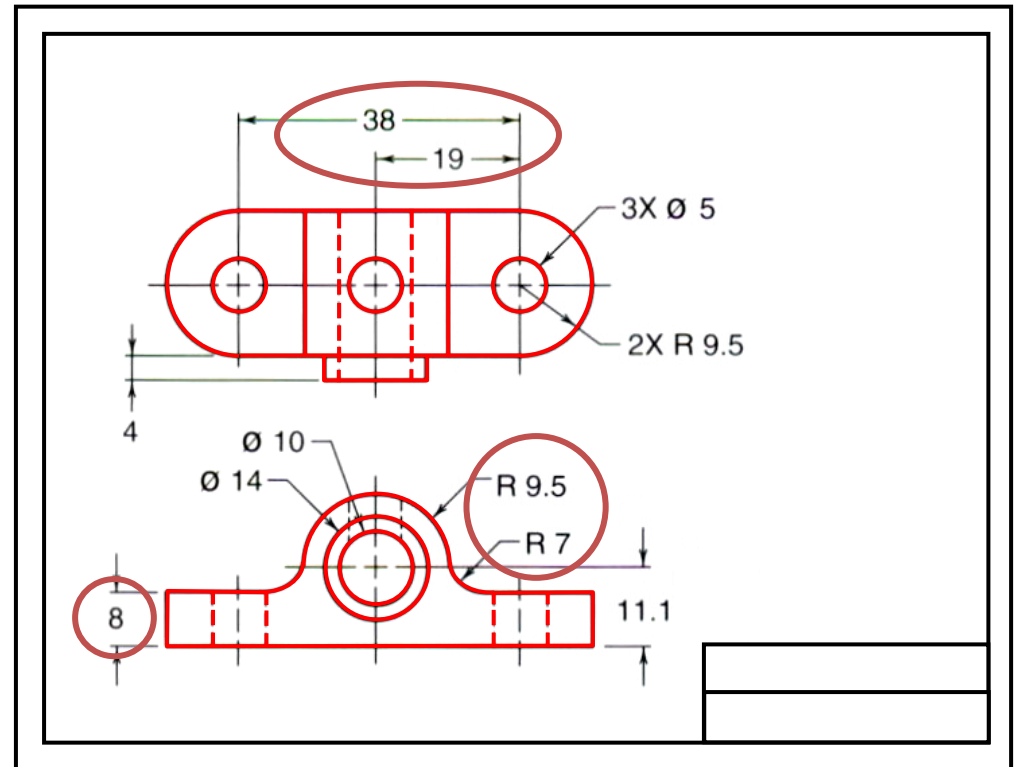

PROJECTION METHOD

PROJECTION THEORY

- The projection theory is used to graphically represent 3-D objects on 2-D media (paper, computer screen).
- The projection theory is based on two variables:
 - 1) **Line of sight**
 - 2) **Plane of projection** (image plane or picture plane)

Line of sight is an imaginary ray of light between an observer's eye and an object.

There are 2 types of LOS : Parallel and Perspective

Parallel projection

Line of sight

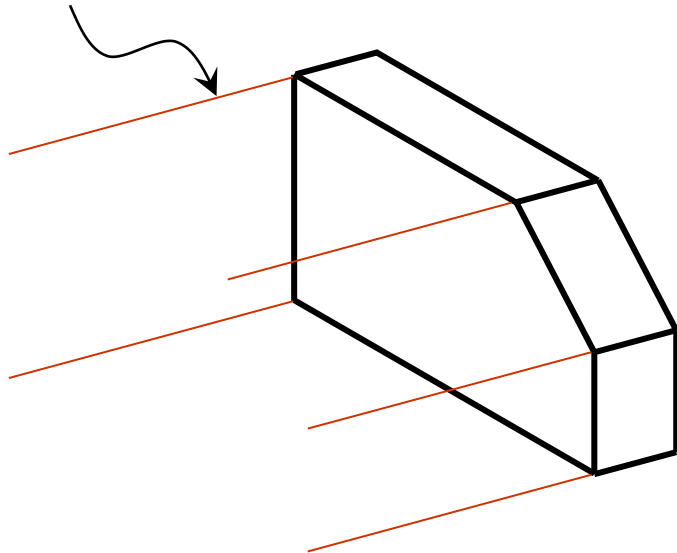

Perspective projection

Line of sight

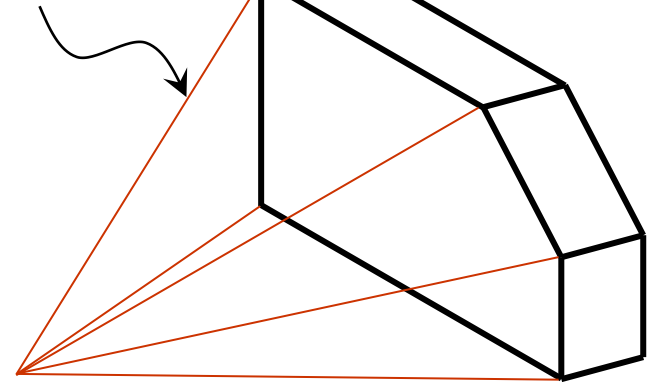

Plane of projection is an imaginary flat plane which the image is created.

The image is produced by connecting the points where the LOS pierce the projection plane.

Parallel projection

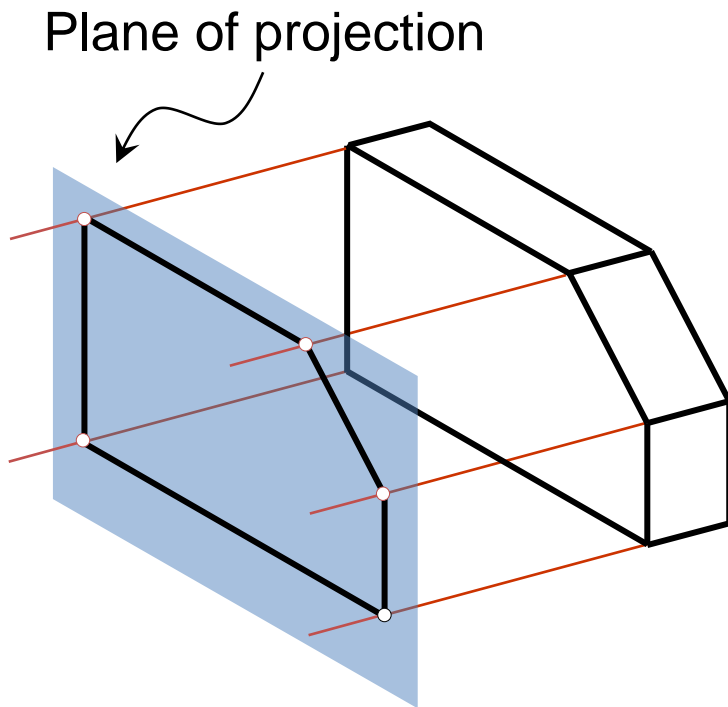

Perspective projection

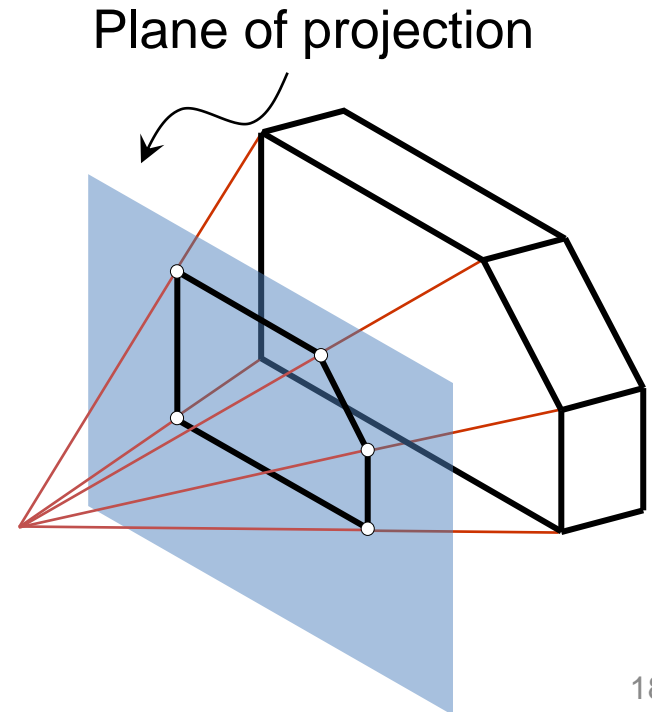

Disadvantage of Perspective Projection

❖ Perspective projection is *not* used by engineer for manufacturing of parts, because

- 1) It is difficult to create.
- 2) It does not reveal exact shape and size.

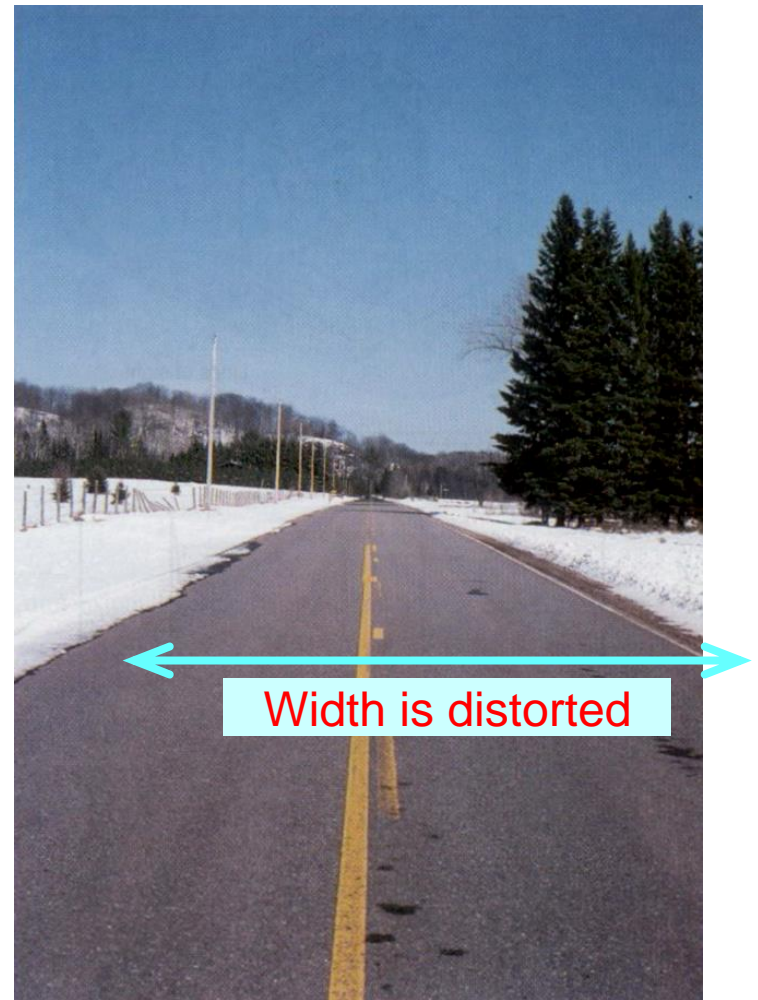

Orthographic Projection

- PROJECTION SYSTEMS

1. **First** angle system

- European country

2. **Third** angle system

- Canada, USA, Japan, Th

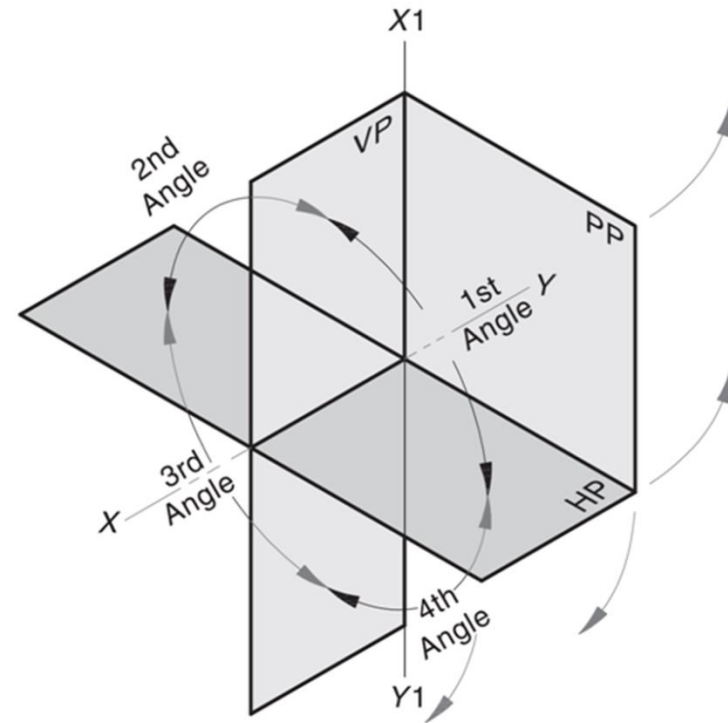

HP- Horizontal Plane;

VP-Vertical Plane;

PP-Profile plane

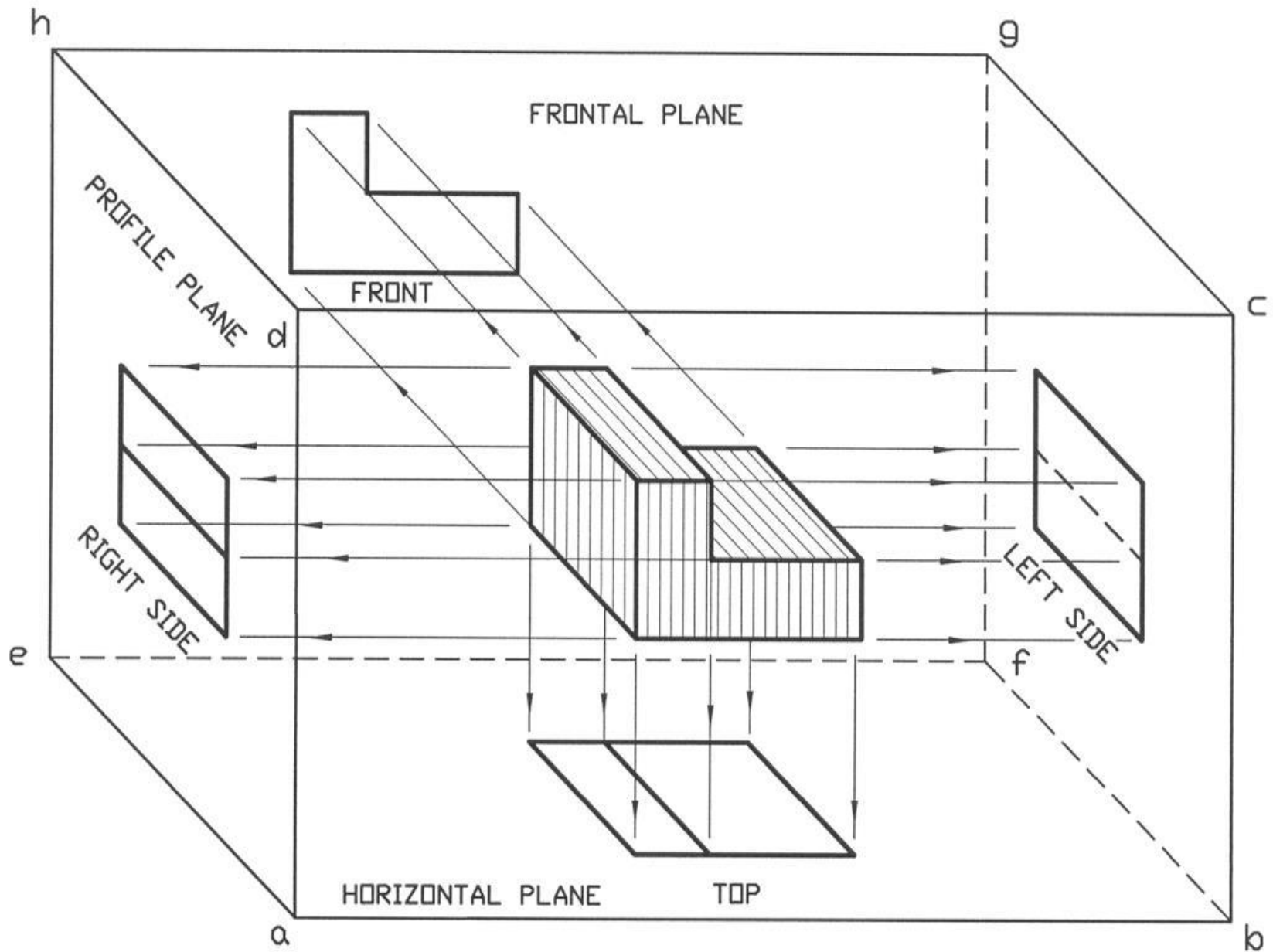

First Angle projection

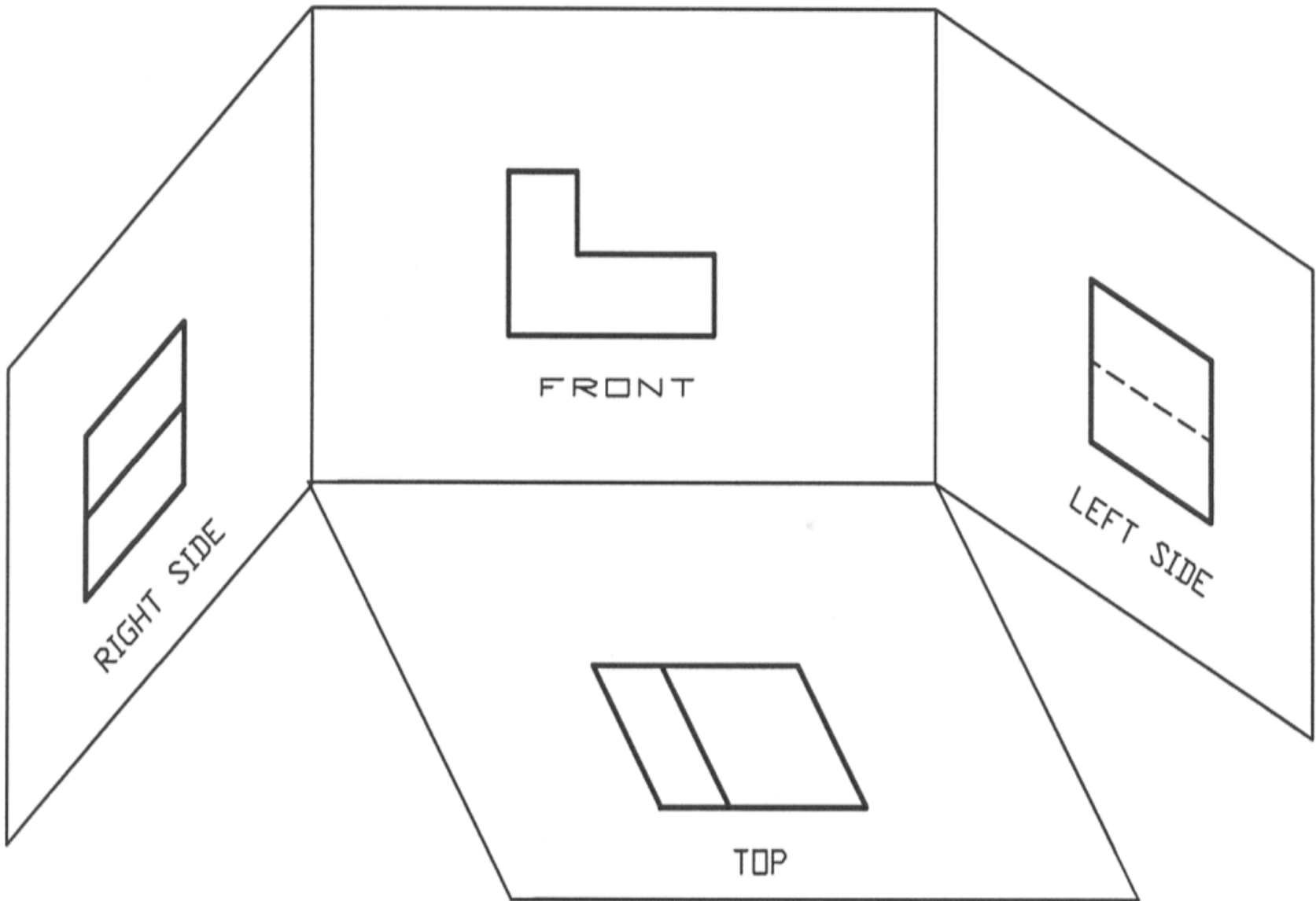

Views on Sides of Unfolding Box in First Angle Projection

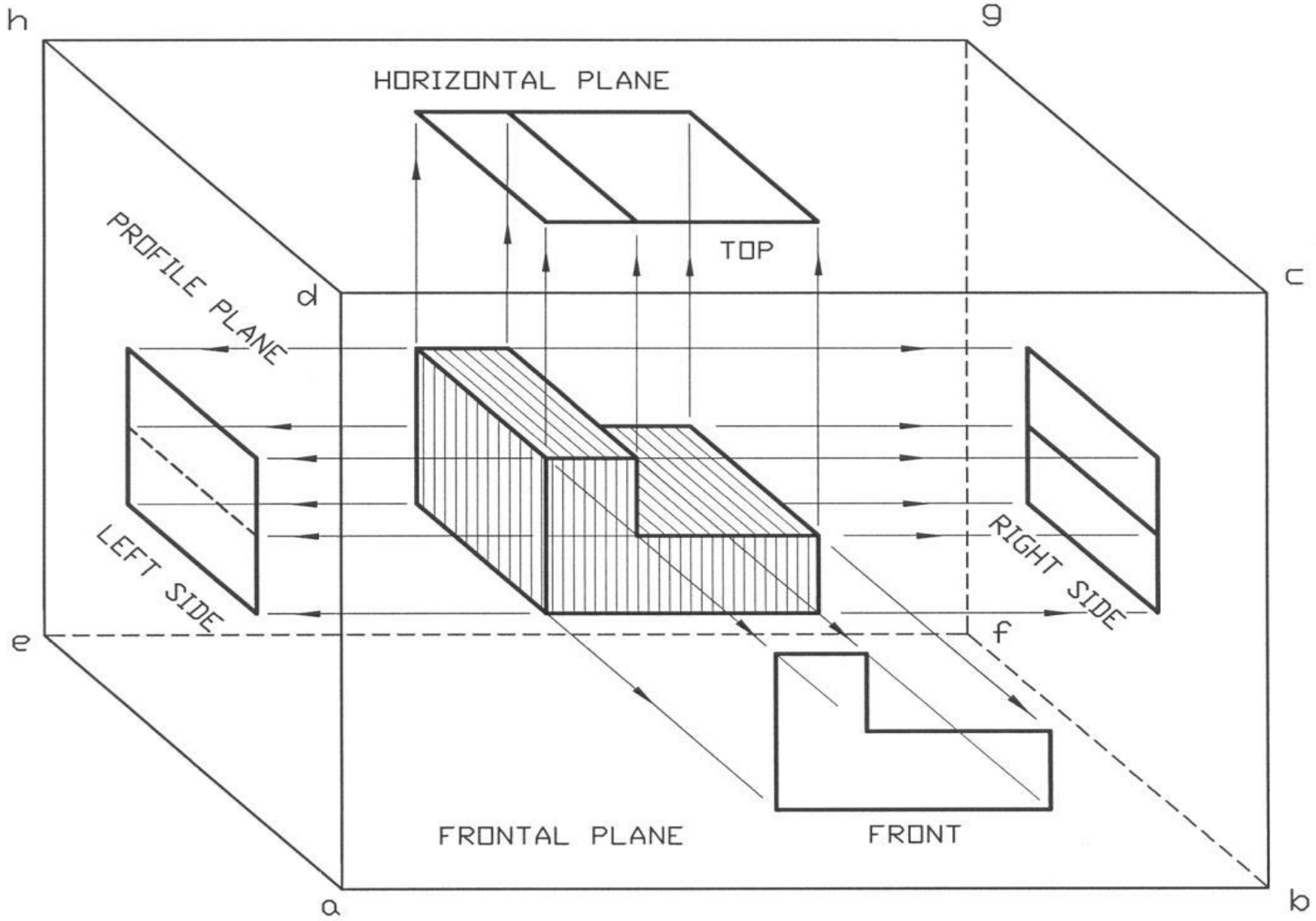

Third Angle Projection. Which is Easier?

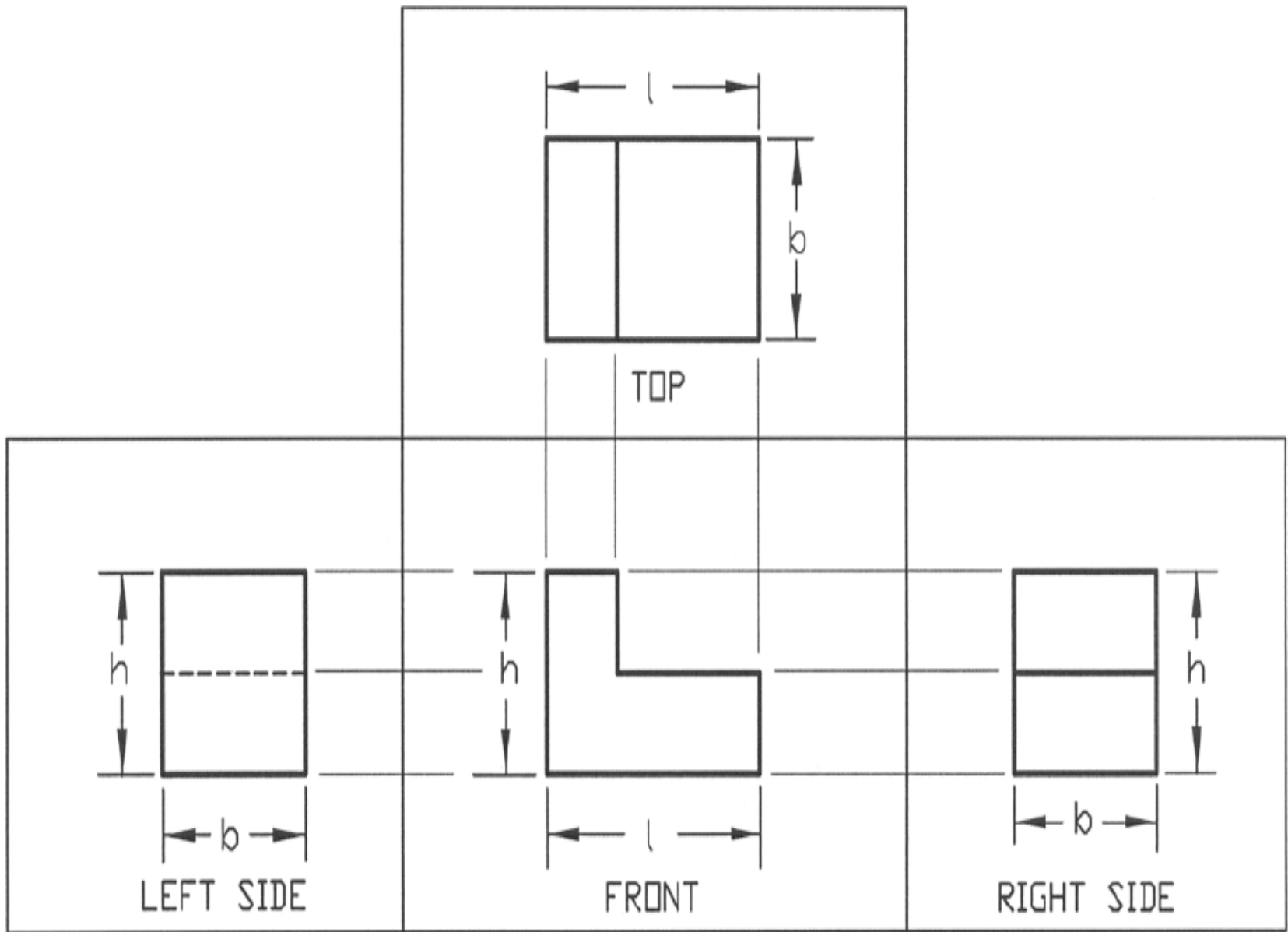

Relative Positions of Views on Sides of Unfolding Box in Third Angle Projection

MEANING

Orthographic projection is a parallel projection technique in which the parallel lines of sight are *perpendicular* to the projection plane.

The best way to understand *orthographic projection* is to imagine an object contained inside a glass box.

Each wall represents a *projection plane* onto which a two-dimensional object view will be created.

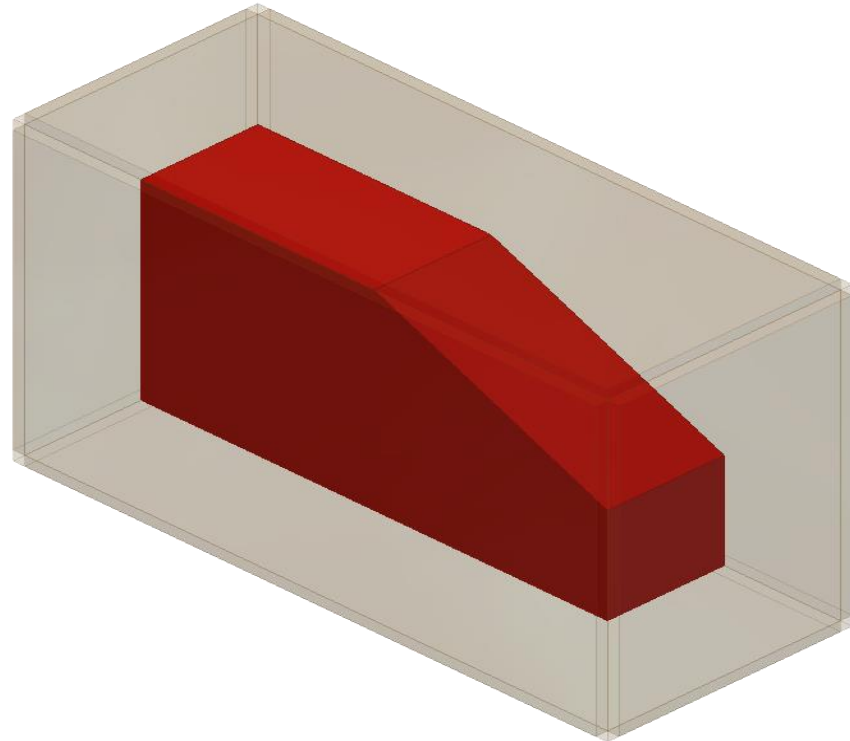

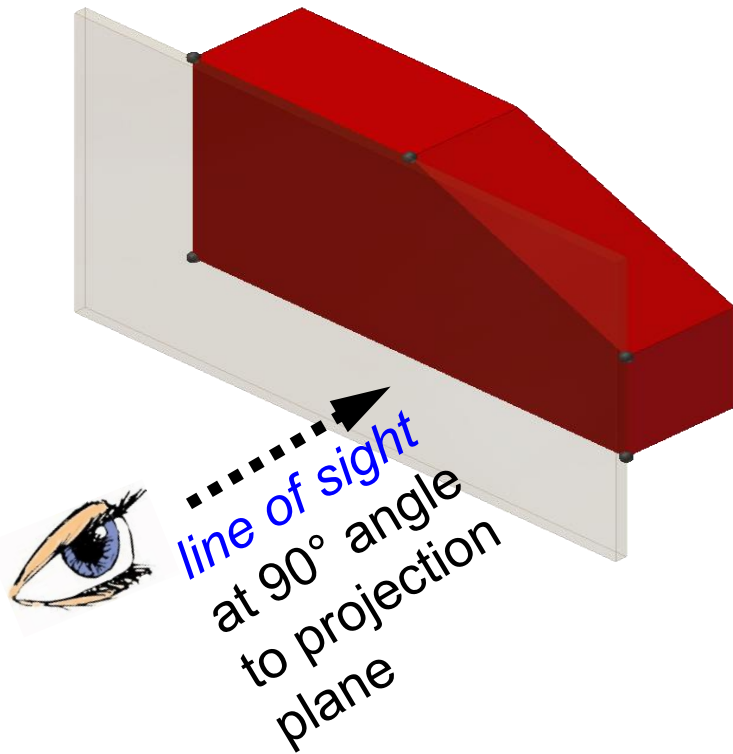

Start by focusing only on the front **projection plane**.

A person standing in front of the object would see only the five corners identified in black.

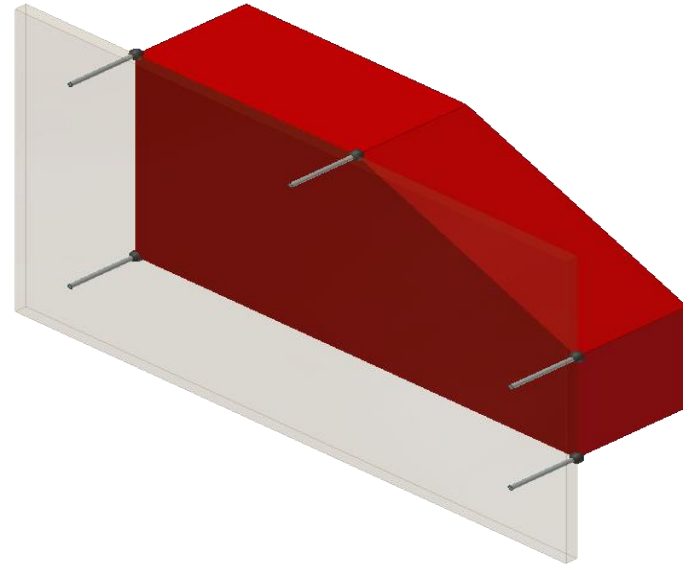

Projection lines are used to project each corner outward until they reach the **projection plane**.

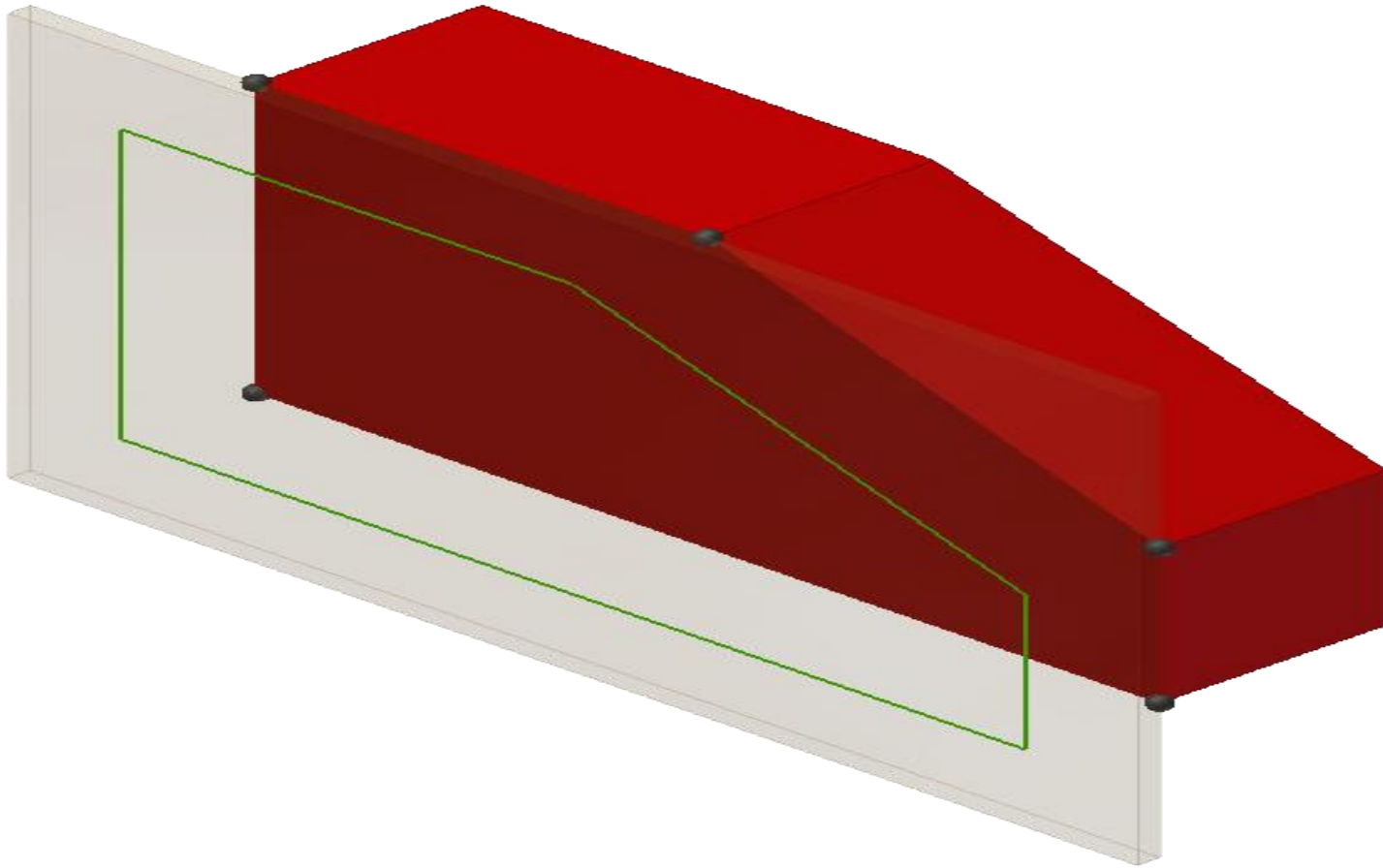

The *visible edges* of the object are then identified on the **projection plane** by connecting the projected corners with **object lines**.

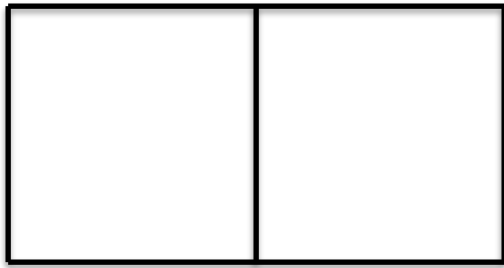

TOP VIEW

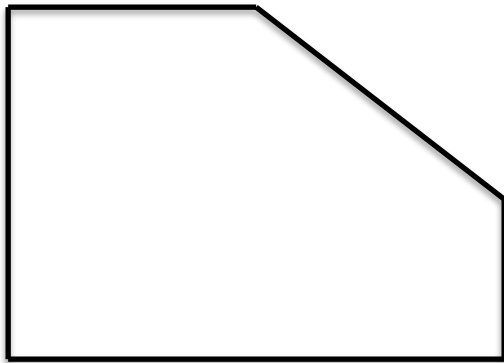

FRONT VIEW



RIGHT HAND
SIDE VIEW

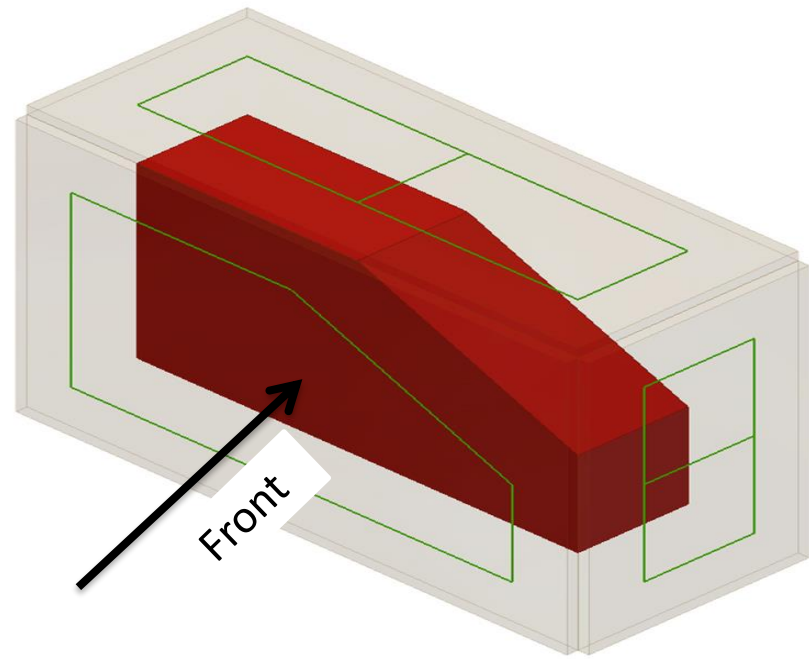

Notes:

1. **Front** view is always central

2. **Top** view goes above

3. **R.Side** view goes to the right

4. **L.Side** view goes to the left.

Multiview Drawing

Advantage It represents accurate **shape and size**.

Disadvantage Require practice in writing and reading.

➤ Hidden lines show details that are not seen in all views

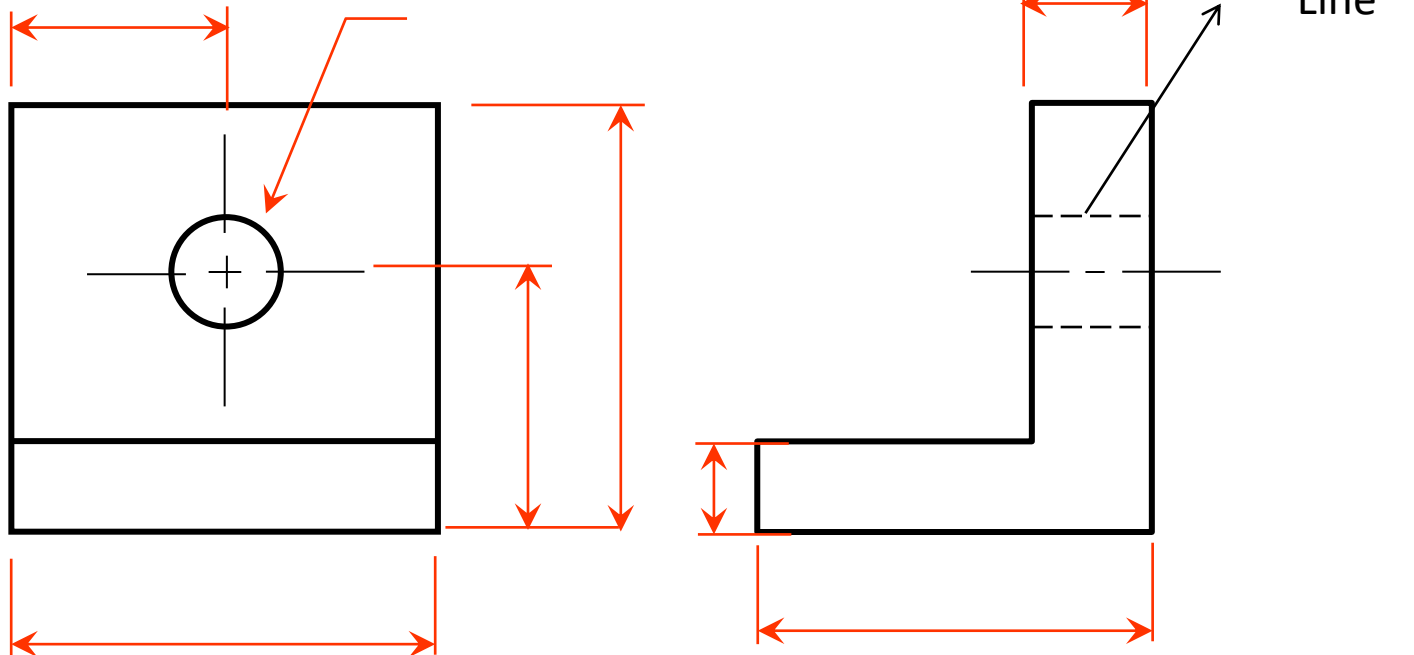

Isometric Drawing

Advantage Easy to understand

Disadvantage Shape and angle distortion

Example Distortions of shape and size in isometric drawing

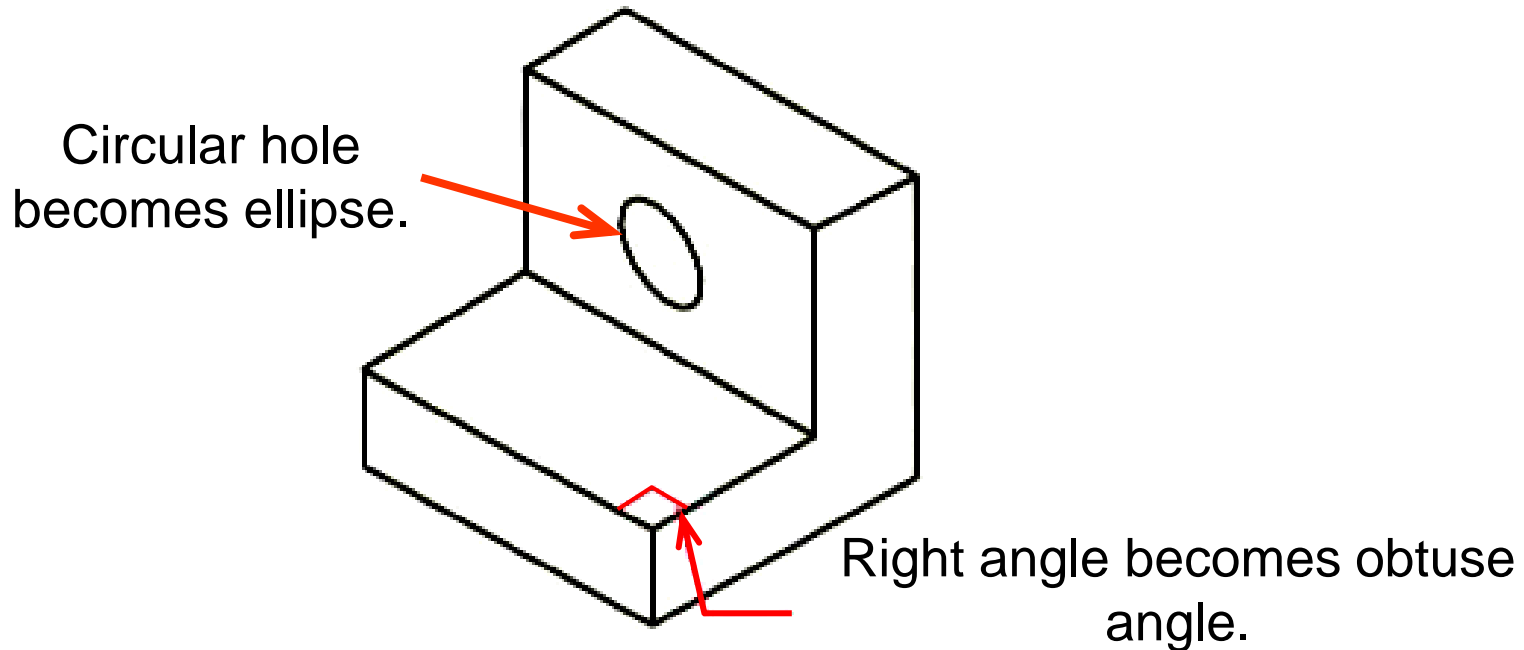

Traditional Drawing Instruments...

- Drawing board/table.
- Drawing sheet/paper.
- Drafting tape.
- Pencils.
- Eraser.
- Sharpener.
- T-square.
- Set-squares/triangles.
- Scales.
- Compass and divider.

Drawing board

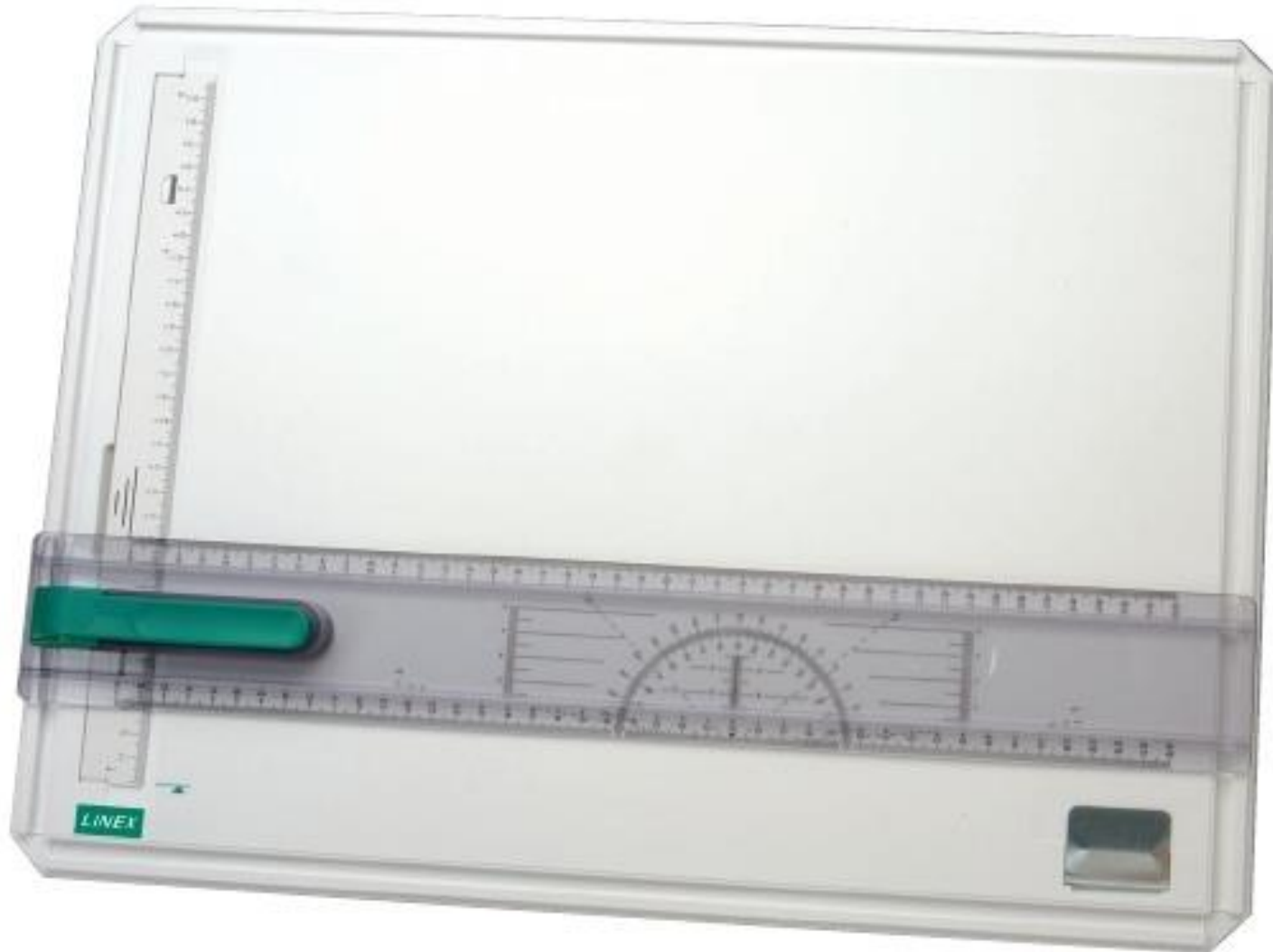

Drawing table



Drawing sheet/paper

- 216 X 280 mm
- 280 X 382 mm
- 382 X 560 mm
- **585 X 726 mm**



DO NOT SCALE

REVISIONS			
SYM	DESCRIPTION	DATE	APPD
A	M12 WAS $\frac{1}{2}$ WHIT.	14-12-78	A.W.B.

4			
3			
2			
1	A7325 VALVE BODY		1
DRG or PART No.	DESCRIPTION	QTY	

UNLESS OTHERWISE STATED ALL DIMENSIONS IN MILLIMETRES. TOLERANCES LINEAR: ANGULAR:		DRN 1:1:78 JKL	[NAME OF FIRM]	
	MATERIAL	CKD 2:1:78 MJM	[TITLE OF DWG.]	
	CAST STEEL	APPD 5:1:78 AWB	SIZE	DRG No
	DRAFTING STANDARD	ISSUED 4:2:78 PFP	A3	A24681
AS 1100	FINISH	SCALE 1:2	SHEET 1 of 1	
AS MACHINED				

Drafting tape



T-square



Some Techniques for Drawing

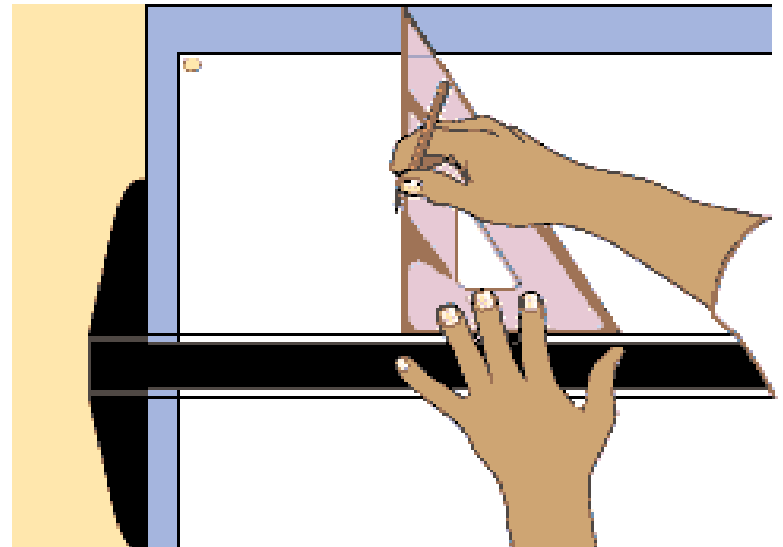
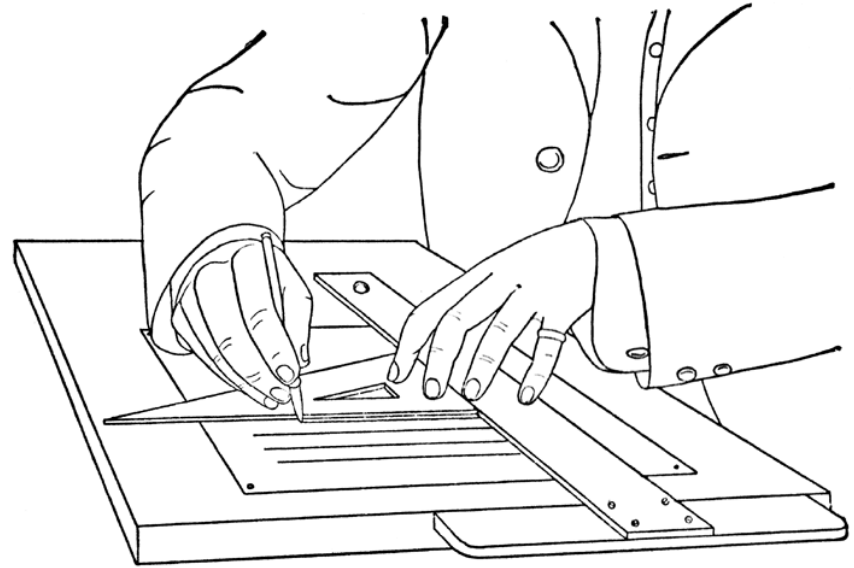
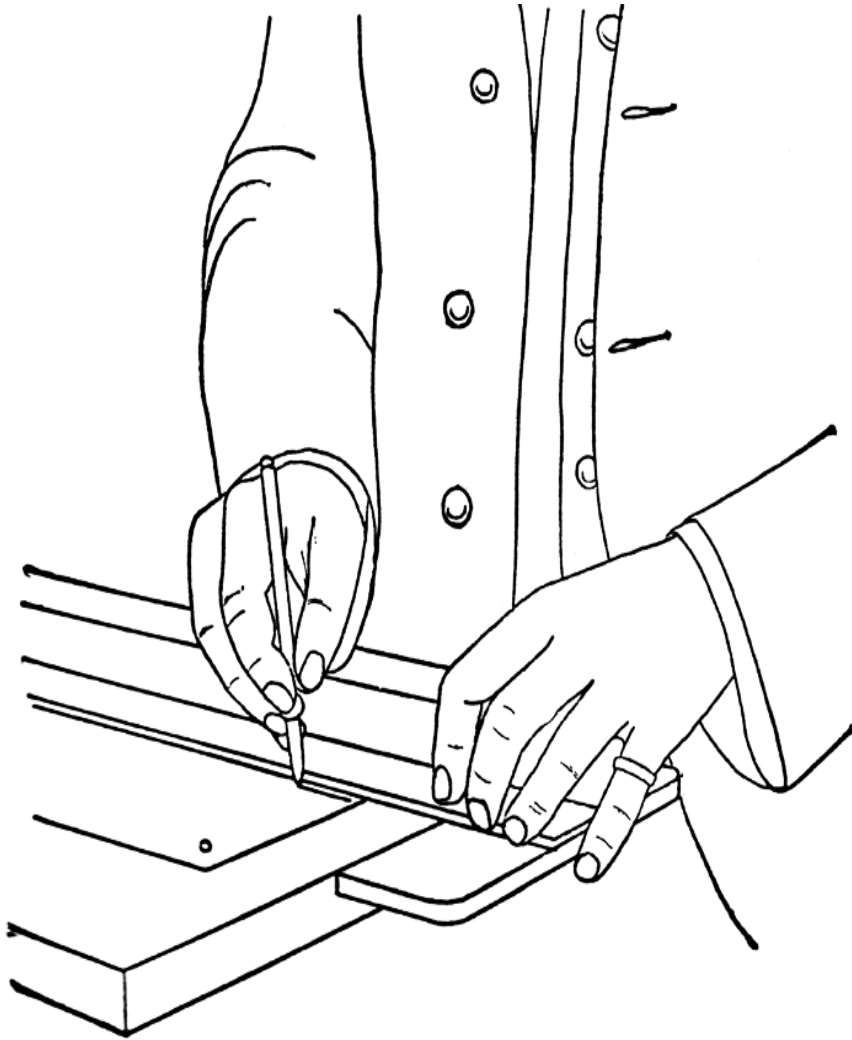

Set-squares/triangles

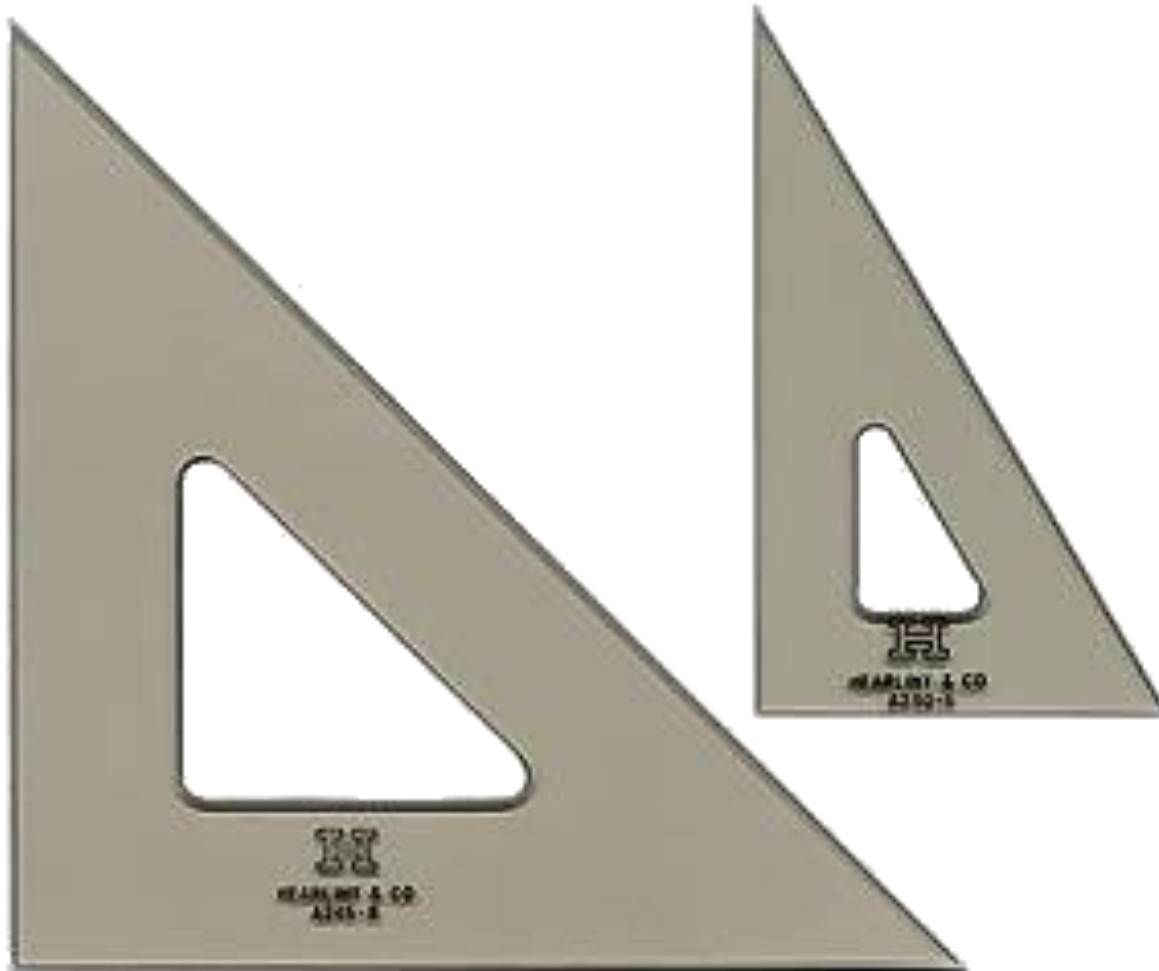

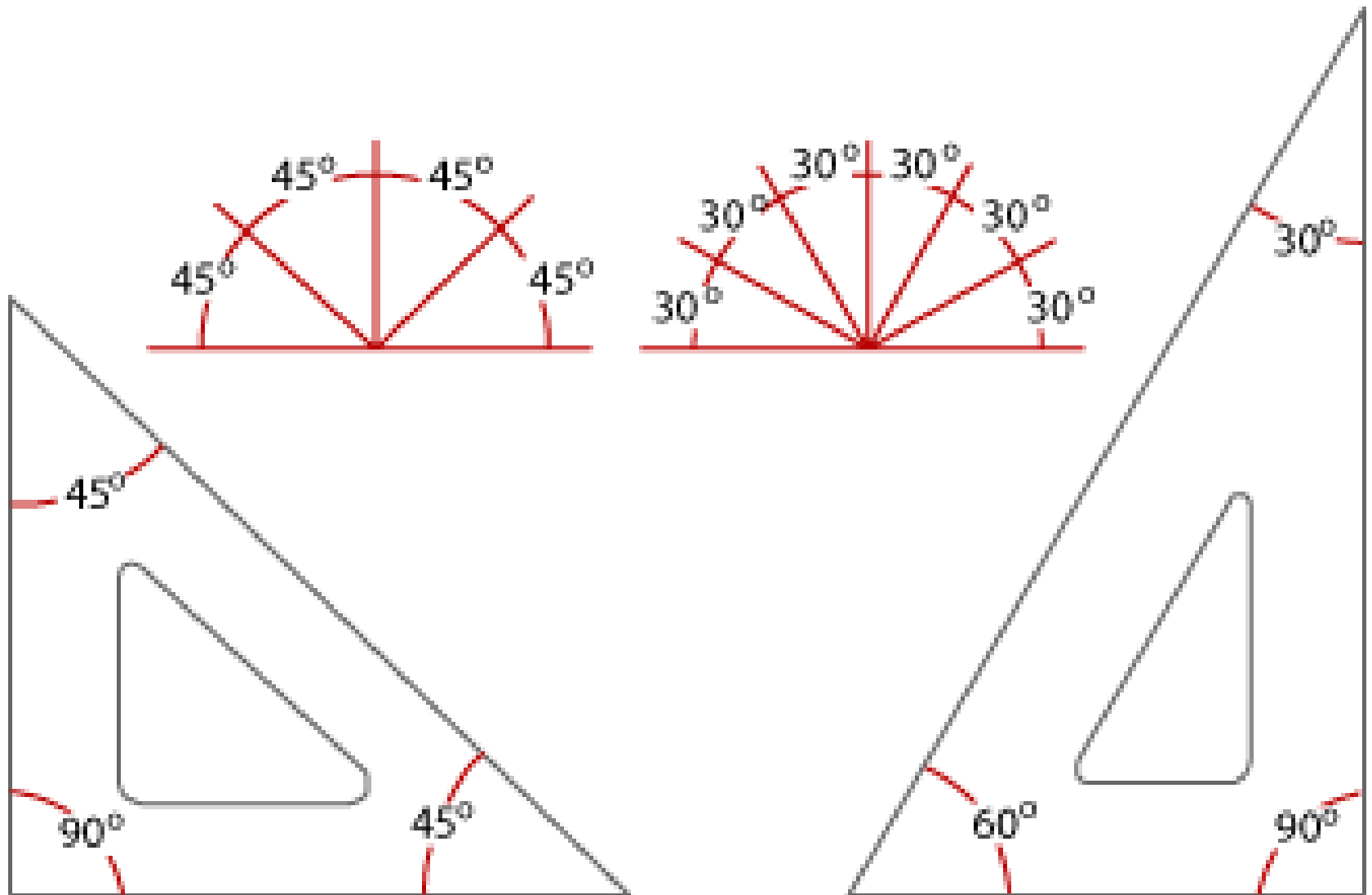

Compass and divider



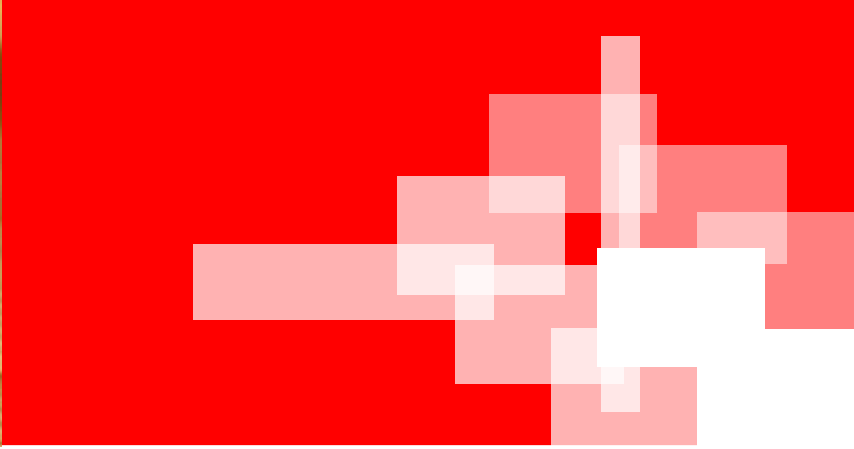

Drawing Standard

Introduction

Standards are set of rules that govern how technical drawings are represented.

Drawing standards are used so that drawings **convey the same meaning to everyone** who reads them.

Standard Code

ISO International **S**tandards **O**rganization

Drawing Scales

Length, size

Scale is the ratio of the linear dimension of an element of an object shown in the drawing to the real linear dimension of the same element of the object.

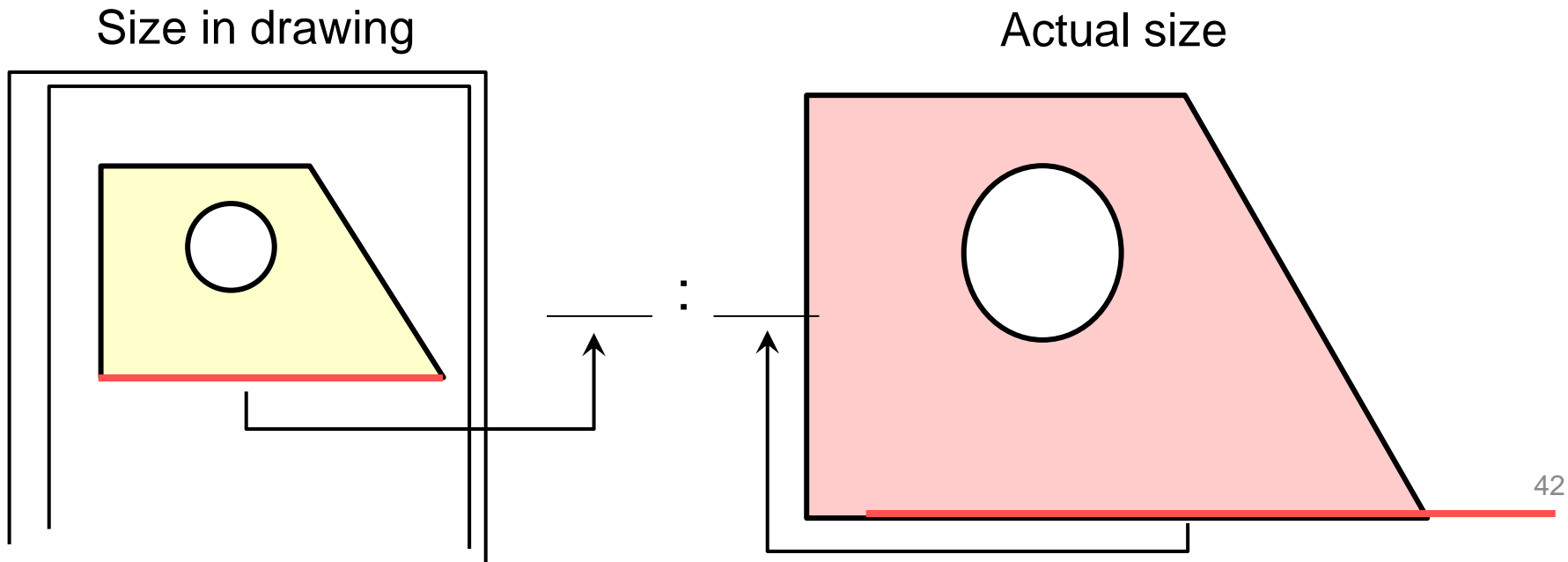

Meaning of Lines

Visible lines represent features that can be seen in the current view

Hidden lines represent features that can not be seen in the current view

Center line represents symmetry, path of motion, centers of circles, axis of axisymmetrical parts

Dimension and Extension lines indicate the sizes and location of features on a drawing



Object Line

Thickness: 100 %



Hidden Line

Thickness: 50 %

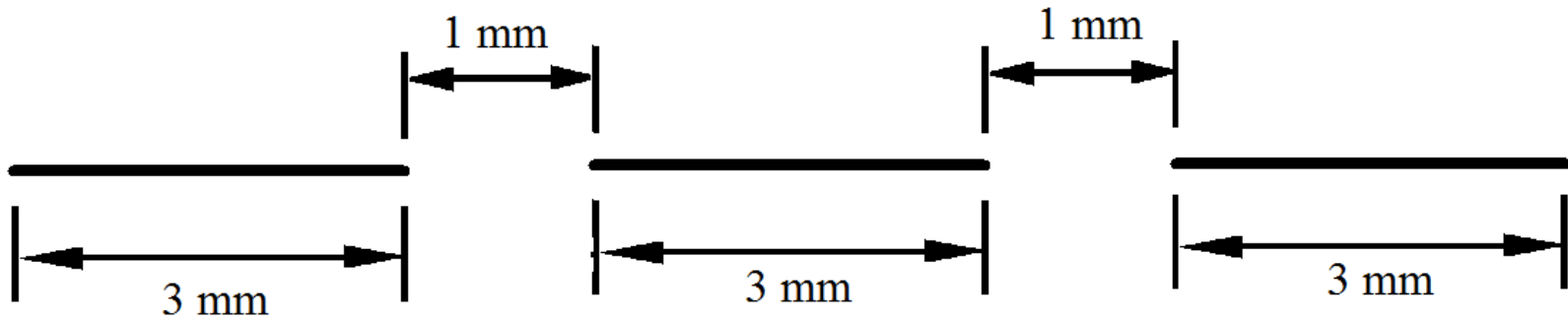

Center Line

Thickness: 50 %

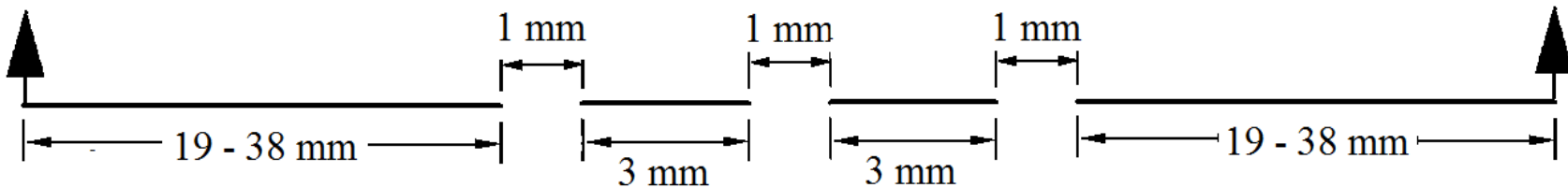



Thickness: 25 %

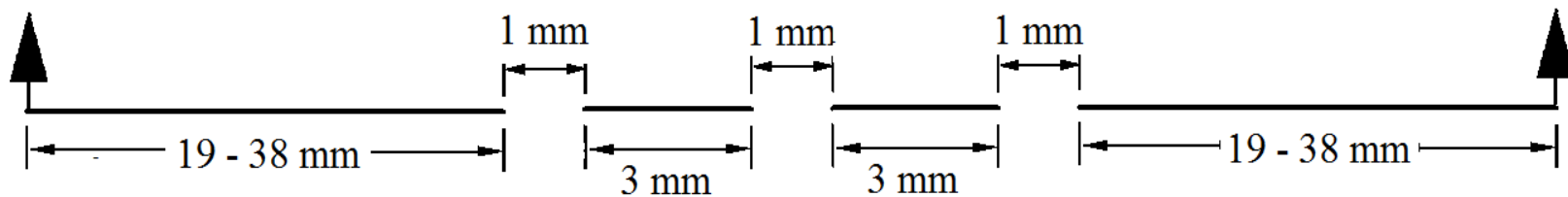

N.B.: All Percentages are with respect to the object line

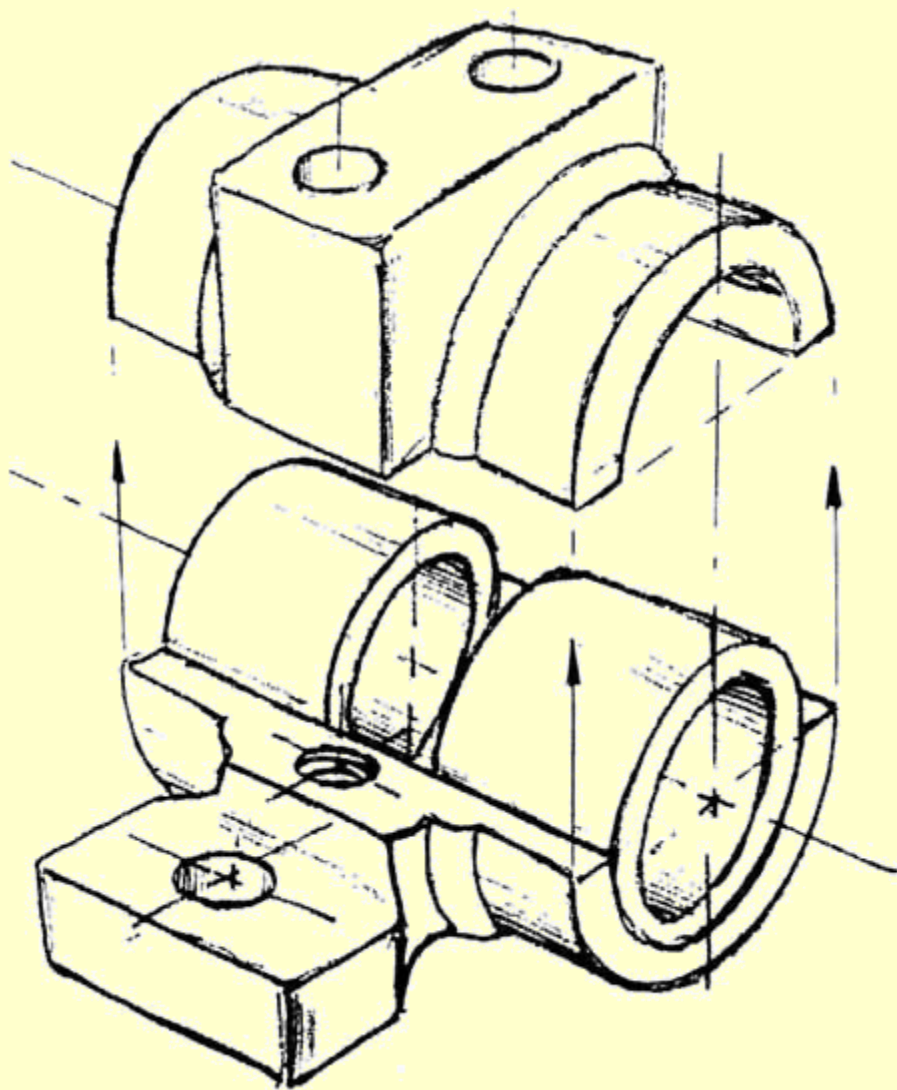

Dimensioning

Dimensioning Guidelines

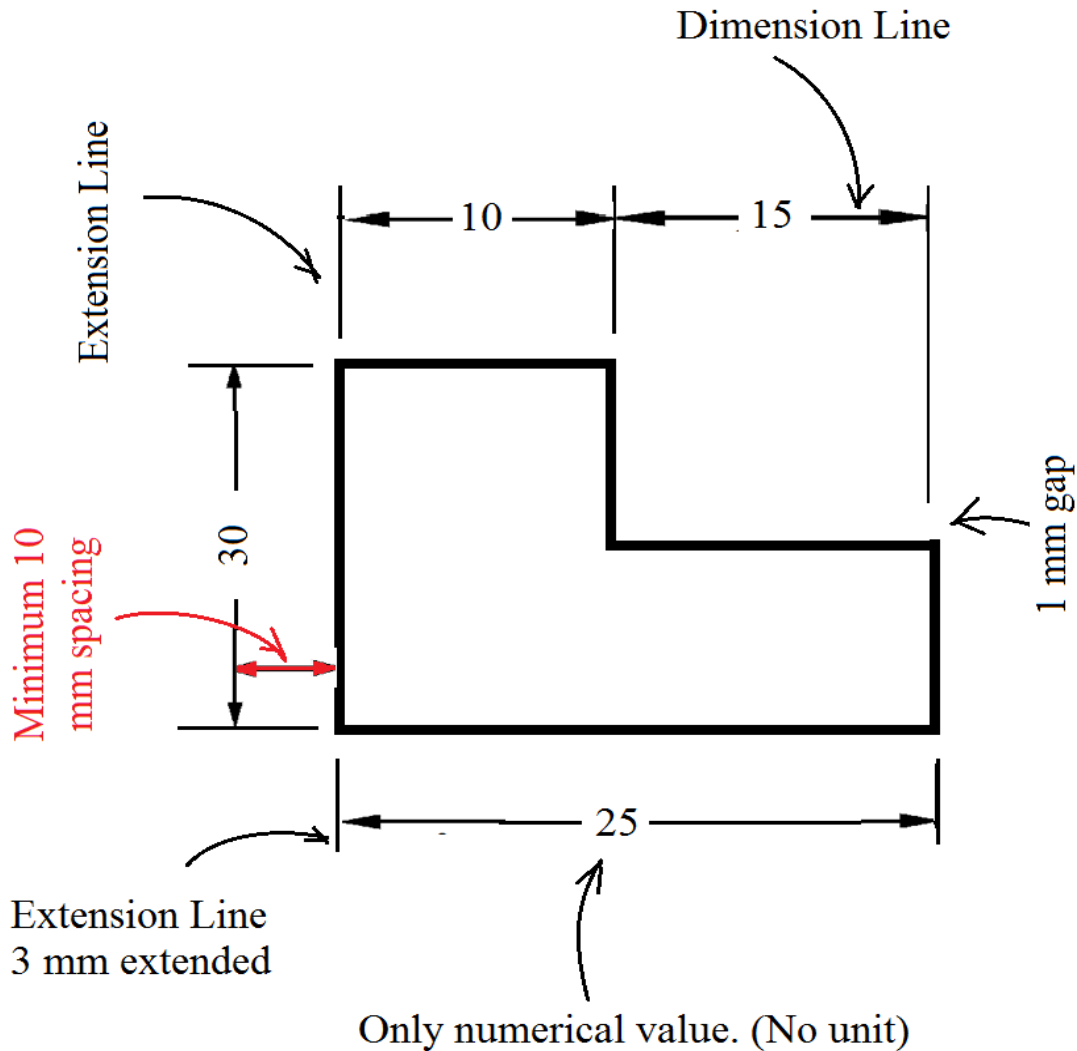

1. Dimension and extension lines must be either horizontal or vertical.
2. No dimension/extension line can cross over another dimension/extension line.
3. There must be one arrowhead at each end of dimension line.
4. The thickness of both extension and dimension line is 25%.
5. No dimensioning is allowed inside the object.

Important elements of dimensioning

Two types of dimensioning: (1) Size and location dimensions and (2) Detail dimensioning

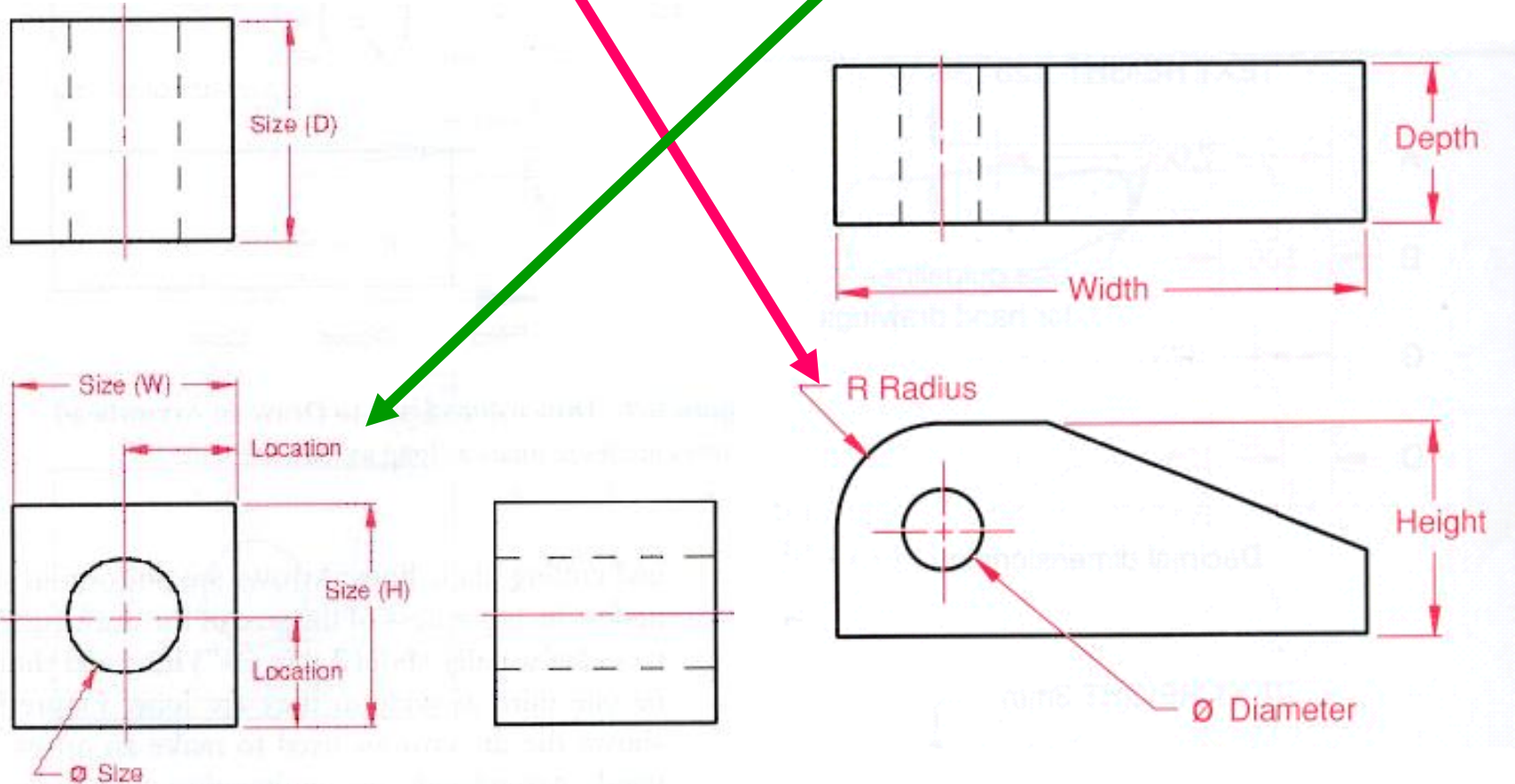

CIRCULAR DIMENSIONING

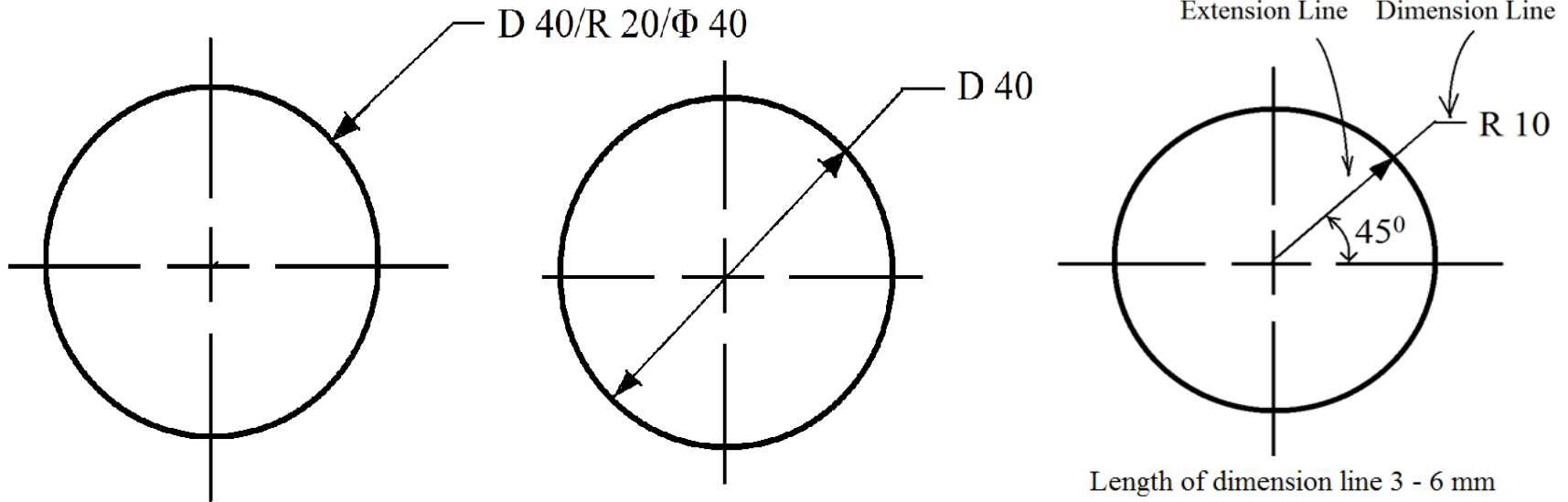

D = Diameter;

R = Radius;

Length of dimension line 3 - 6 mm

R 10 represents Radius = 10

Before dimensioning Centerline must be drawn.

DRILL = Diameter;

REAM = Diameter;

The projection of the extension line in first figure must go through the center of the circle

The arrowhead must touch the circle whose dimension is being shown.

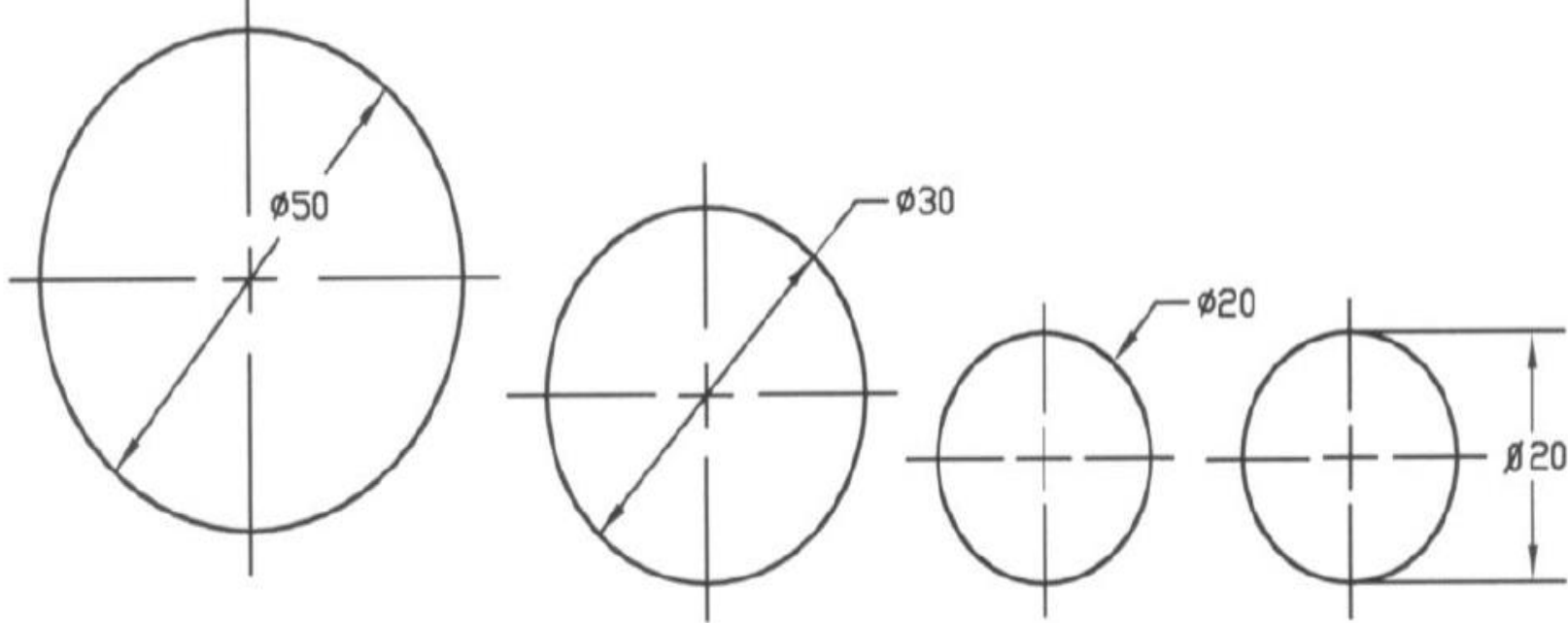

Dimensioning of Circles



Dimensioning of Angles

Grouping Dimensions

- Dimensions should always be placed outside the part

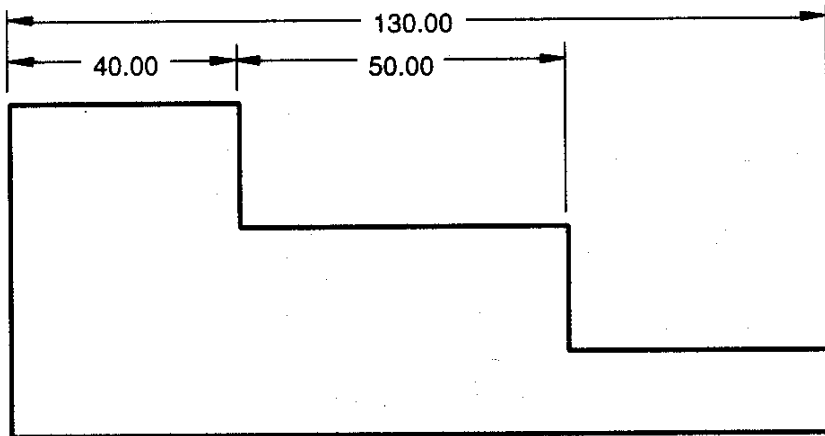

Yes

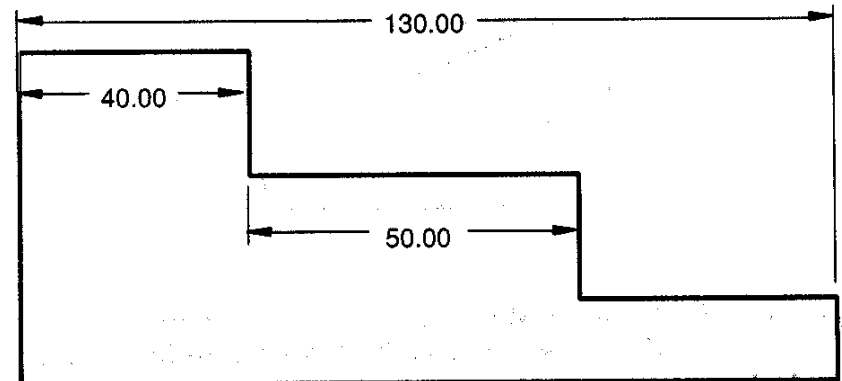

No

Where and how should we place dimensions when we have many dimensions? (cont.)

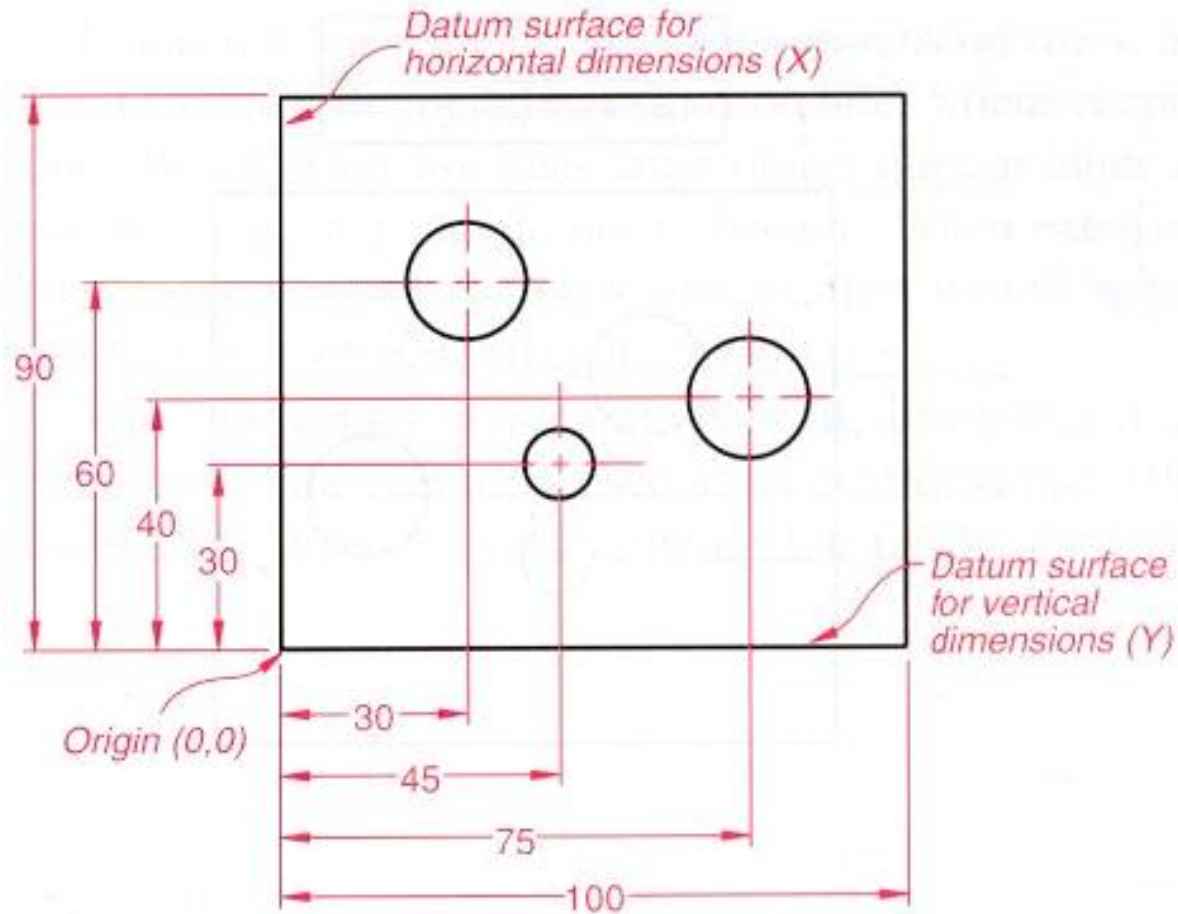

Repetitive Features

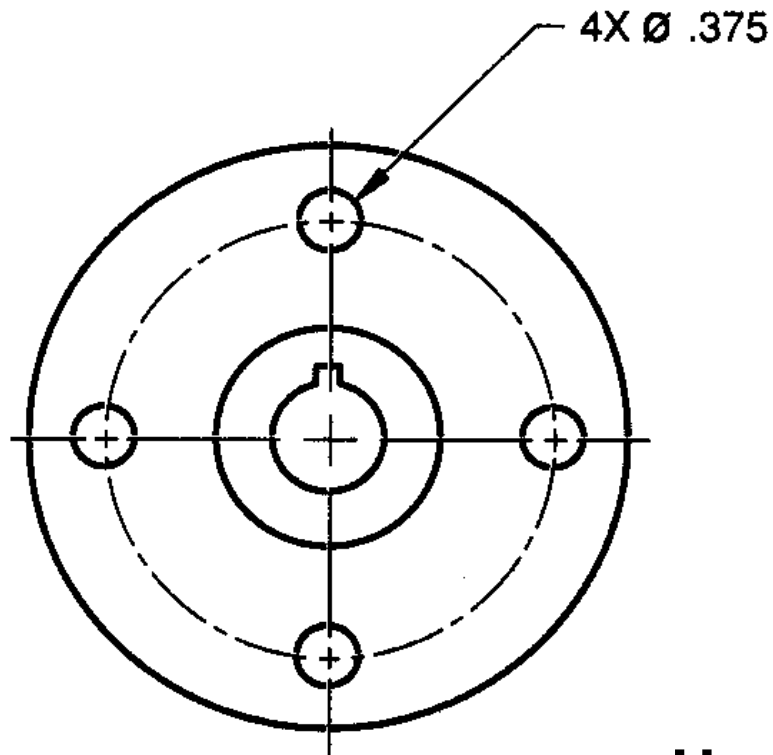

**Use the Symbol 'x' to
Dimension Repetitive
Features**

WHERE TO DRAW A LINE?

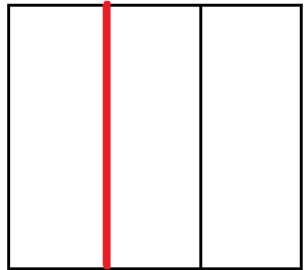
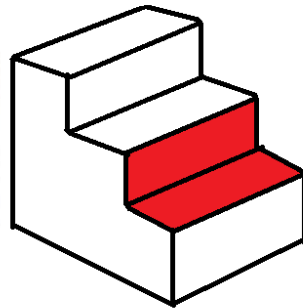
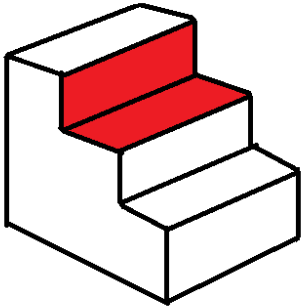

TOP VIEW

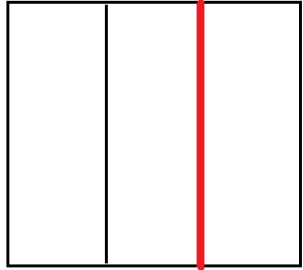

TOP VIEW

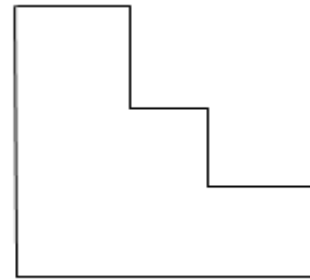
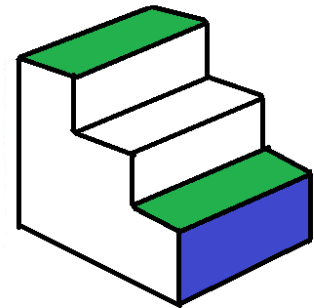
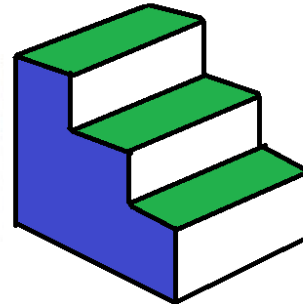

Front View



R.H.S View

Red Line is due to the intersection of two red planes shown in the isometric view.

Each segment of green line is due to the intersection of blue plane and green planes

WHERE TO DRAW A LINE?

- Where a curved surface is *tangent* to a plane surface, no line should be shown where they join

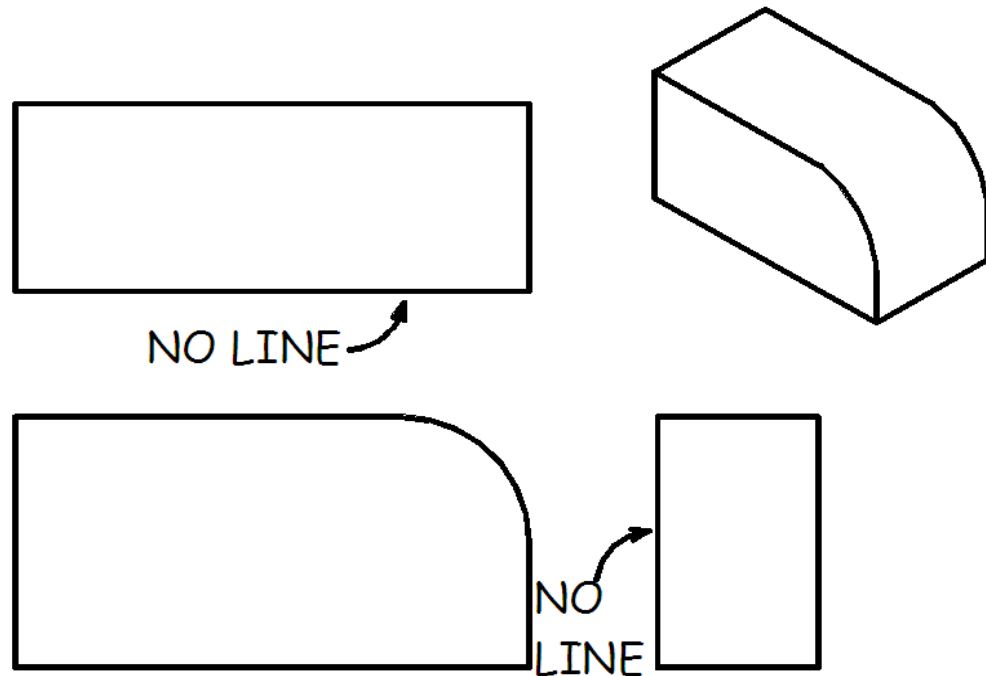

WHERE TO DRAW A LINE?

- Where a plane surface intersects a curved surface, an edge is formed

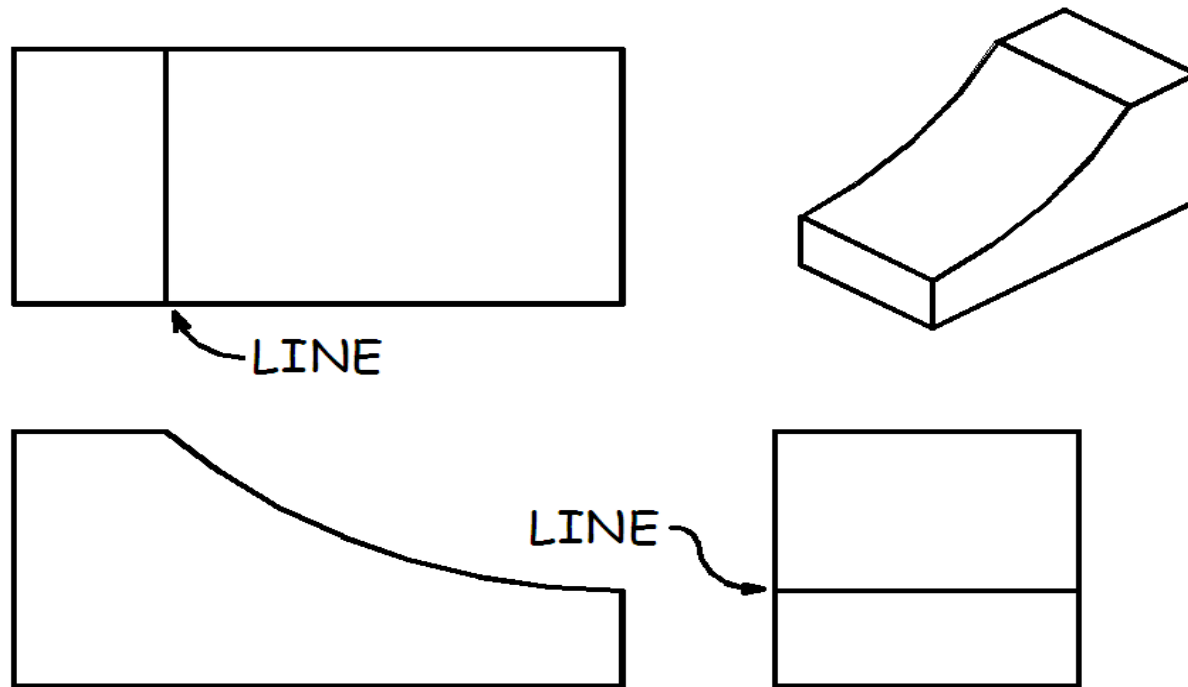

How to Start Drawing???

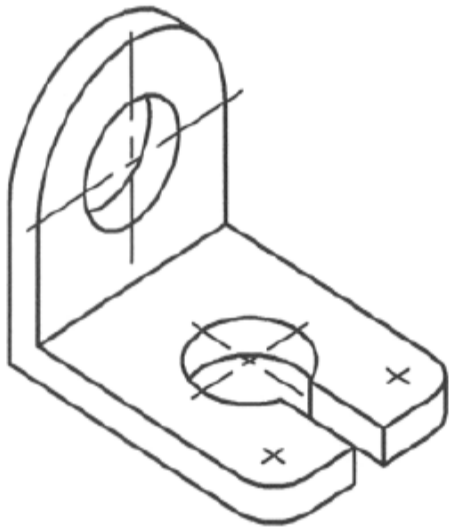

Step-1

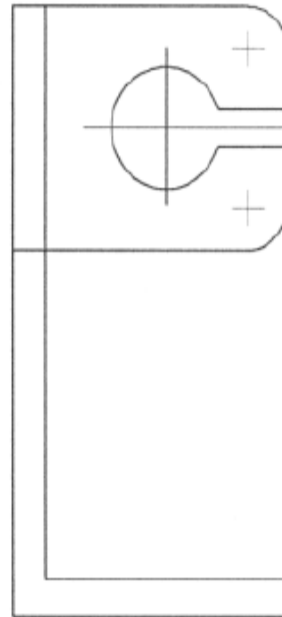

Step-2

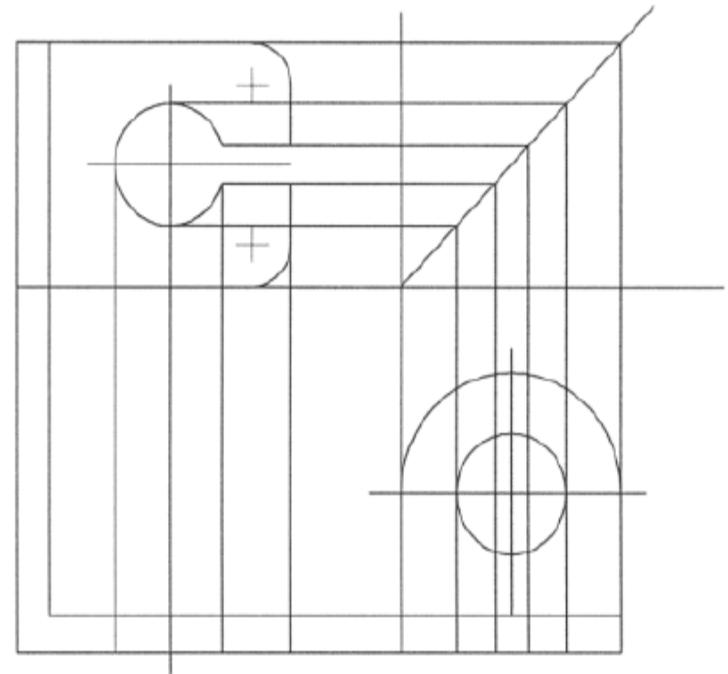

Step-3

Front View

How to Start Drawing???

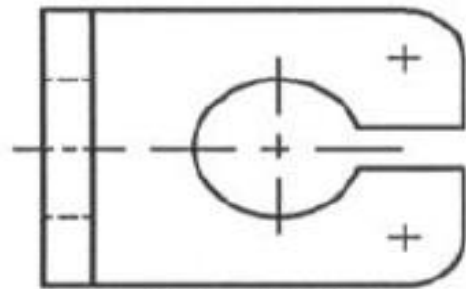

TOP VIEW

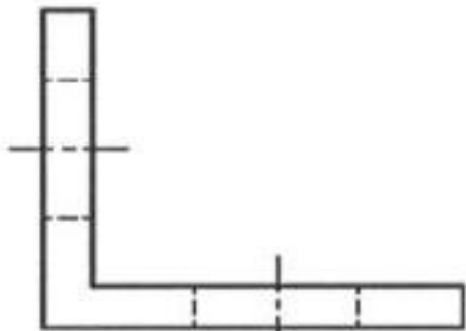

FRONT VIEW

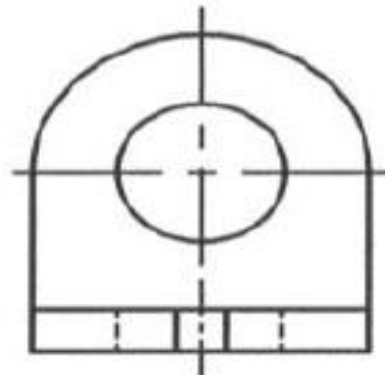

RIGHT SIDE VIEW

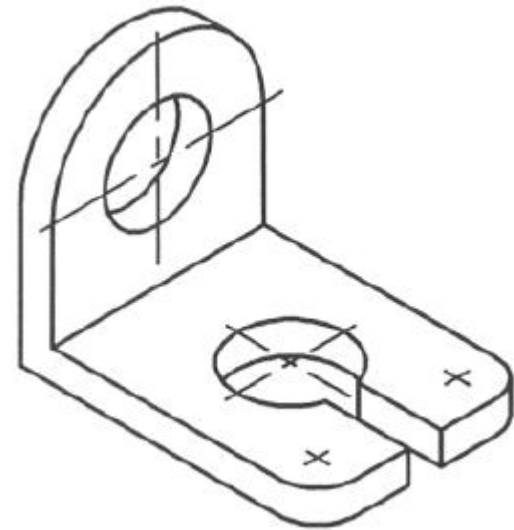

Its Done. Simple, right???

Sectional views

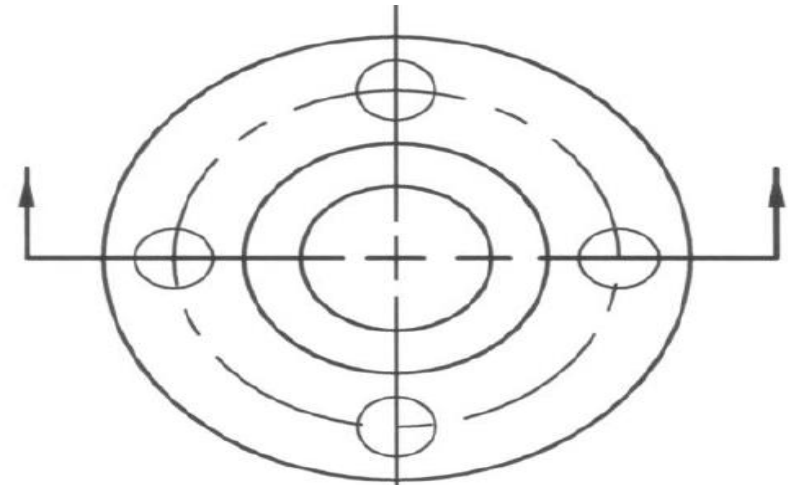
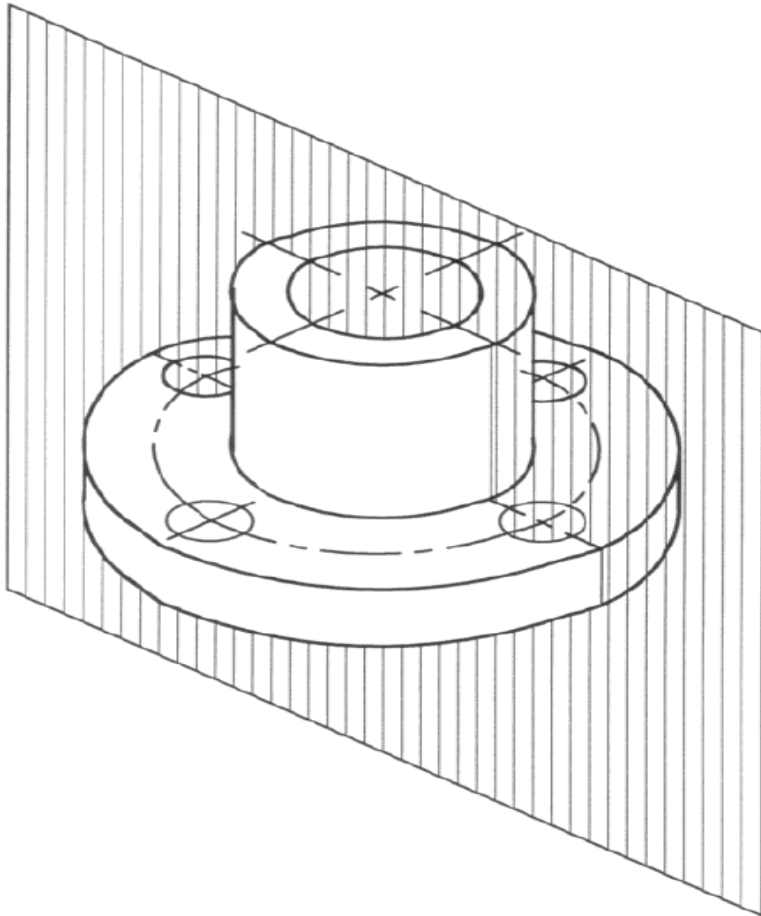

Top View

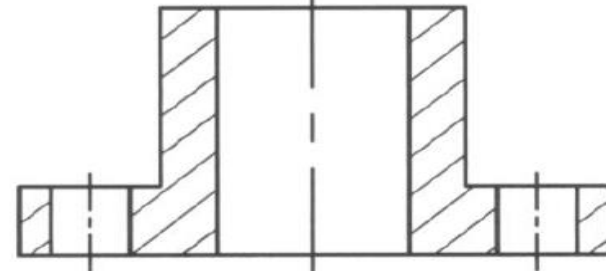

Sectional View

Section After Cutting and Removal of Front Portion



Cast Iron

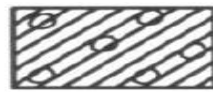

Sound Insulation

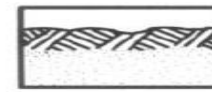

Earth



Steel



Cork, Felt,
Leather & Fiber



Rock



Bronze, Brass,
Copper and
Compositions



Fire Brick
and Refractory
Materials

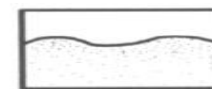

Sand



White Metal,
Zinc, Lead,
Babbit and
Alloys

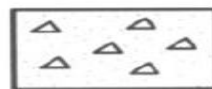

Concrete

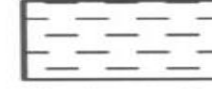

Water &
Other Liquids



Magnesium,
Aluminium



Marble, Slate,
Glass, Porcelain

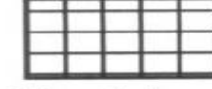

Electric
Windings,
Electromagnets etc.



Rubber, Plastic,
Electrical Insulation

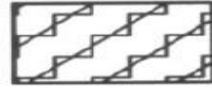

Thermal
Insulation



Wood

Symbols for Section Lining

SOME COMMON MISTAKES

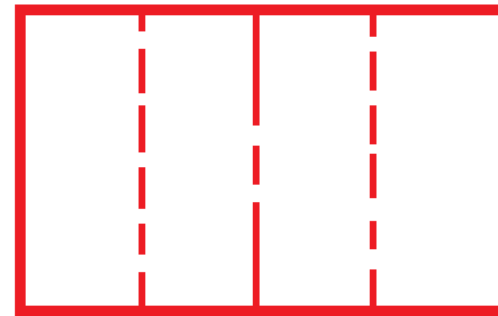
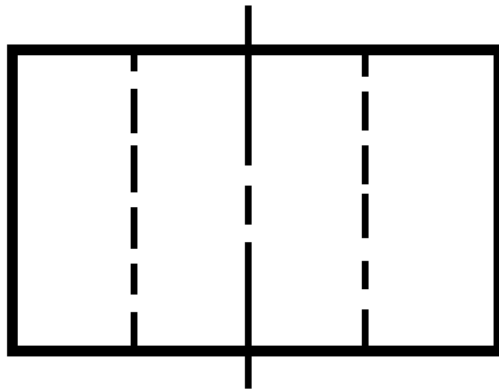
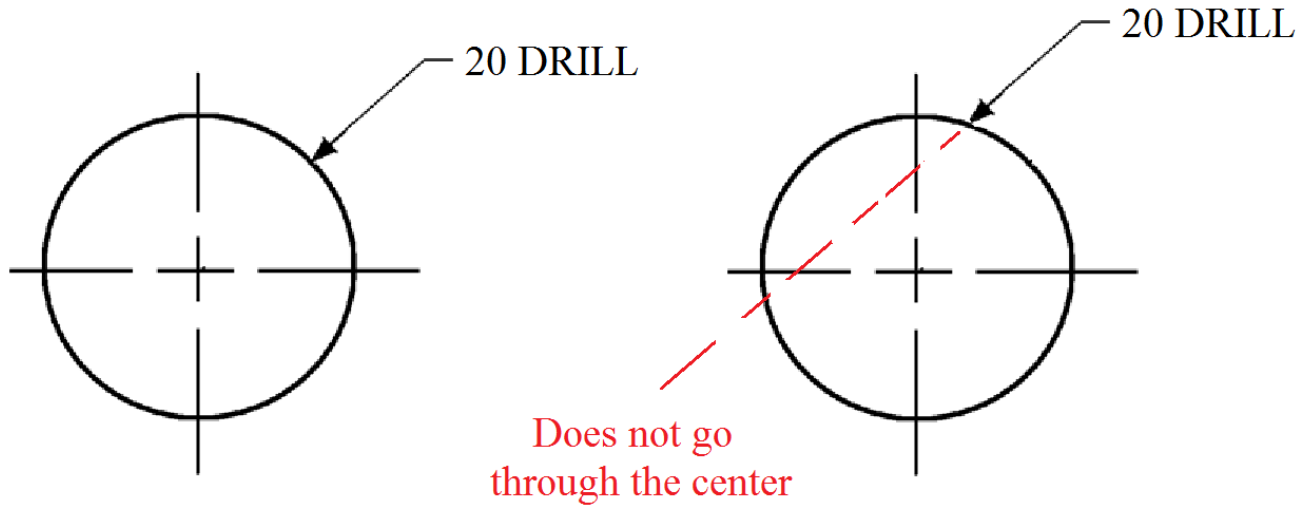

No extension for hidden line ; 3 - 6 mm extension for center line

**Persist until
Succeed!**